

**Tempur® Hampton Ottoman**

---

Assembly Booklet

# Welcome to your Tempur® Hampton Ottoman bed assembly guide.

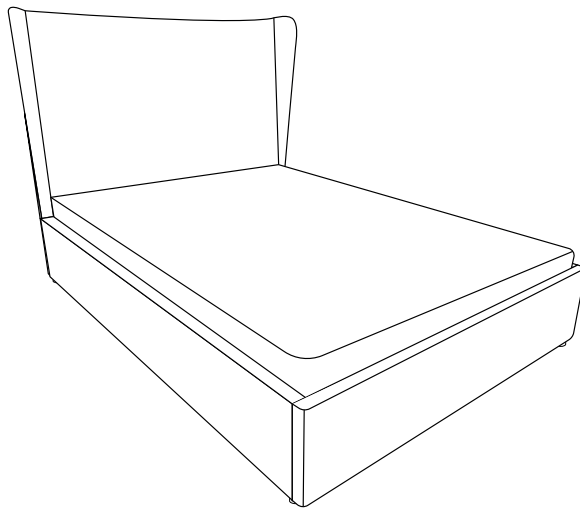

Register your product on the website:  
<https://uk.tempur.com/product-registration.html>

For product use, care, and warranty details,  
read the instructions on the website:  
<https://uk.tempur.com/quality-guarantee.html>



Product is manufactured by Bed Factory Sweden OÜ,  
A subsidiary of Tempur Sealy International Inc.,  
Riia str 66, Viljandi, Estonia



## **CAUTION**

For a safe assembly, we do not advise assembling on your own.  
A minimum of 2 persons are required for a safe assembly.

The assembly instructions must be followed closely to install the bed system successfully, safely and to minimize the risk of personal injuries and damaging of the product.

## Assembly Guide

- All tools required for product assembly, come with the product.
- Open the packaging carefully, so not to damage any of the bed parts.
- Dispose packaging safely.
- Check all components.

## Component list

1 x headboard

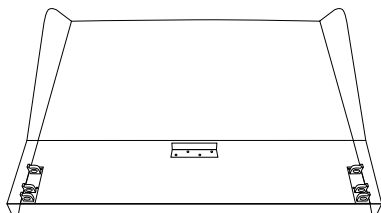

2 x side panels

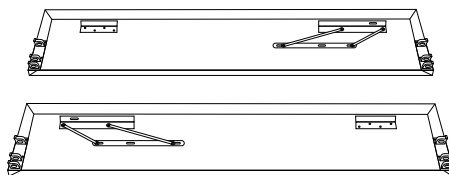

1 x foot end panel

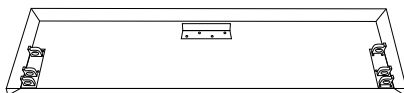

2 x bottom panels

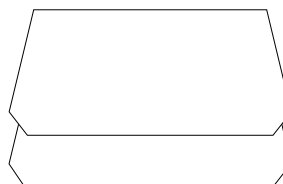

2 x slatted bed frames

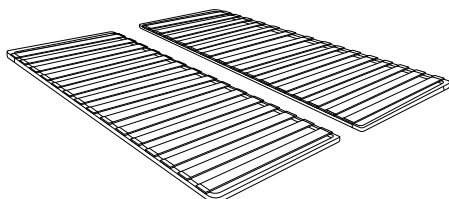

2 x mattress bars

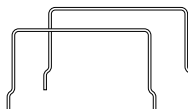

4 x button legs



## Components to join two inner frames

2 x joining brackets

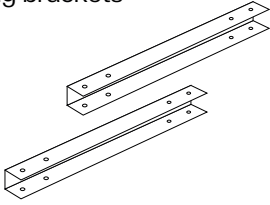

8 x M6 nuts



8 x bolts M6 x 55mm



16 x washers



## Components to join hinges with the frames

2 x pistons

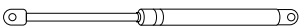

4 x bolts M6 x 50mm



4 x washers



4 x M6 flanged nuts



4 x M8 nuts



1 spanner  
1 allen key

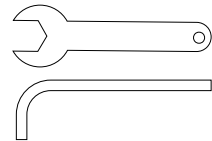

## Assembly steps

1. Lay all outer frame parts on the floor, connectors facing upside.

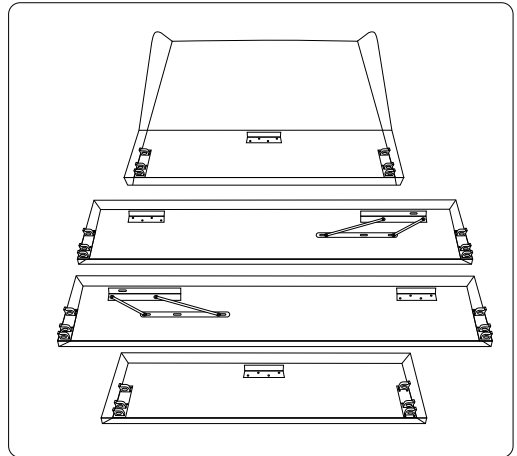

2. Place one side panel to head-board connector. See that the hinges on the panel are on the headboard side. Fix the panel with placing one button leg into corner connector. Push the leg, no need to twist the legs. When the bed is in the upright position, they will be fixed in firmly. Hinges need to be headboard side.

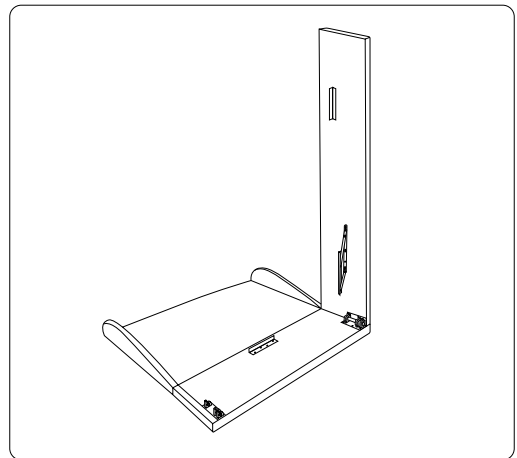

Follow the head and feet icons on the corners. You need to connect the corners with same icons, feet with feet and head with head. Follow the direction of the icons, they need to be upright.

Detail view of corner connector

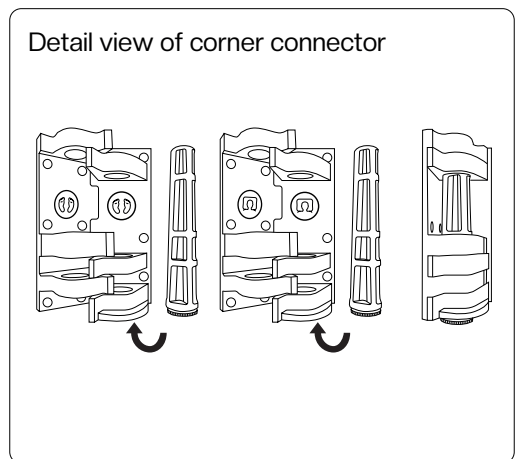

**3.** Connect second side panel with headboard corner connector and fix it with another button leg.

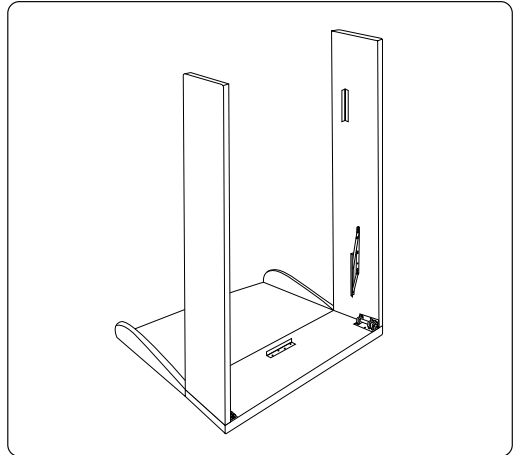

**4.** Turn the bed to its normal position with two people, one in one side and another in other side.

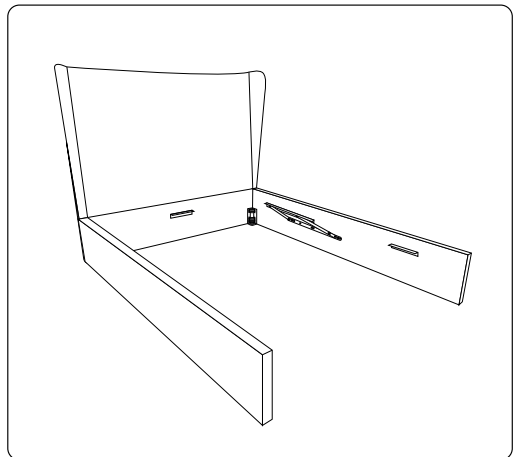

**5.** Add the foot end with two people, both in each corner.  
Connect both foot end corners onto the side panel corner connectors.

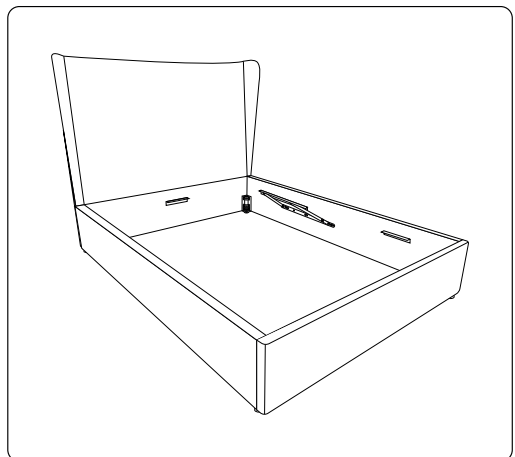

**6.** Fix the foot end by adding legs to both corners. Push the legs into connector. No need to twist, the weight of the construction of the bed will fix the legs to the end position.

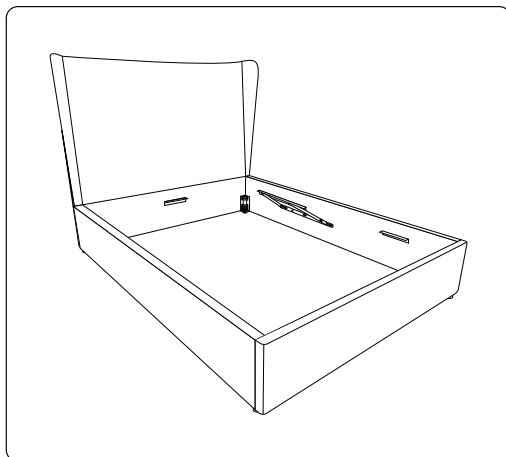

**7.** Add bottom panels. Firstly, install one by pushing the panel diagonally to its position. Then add the second panel by placing it diagonally into opposite direction.

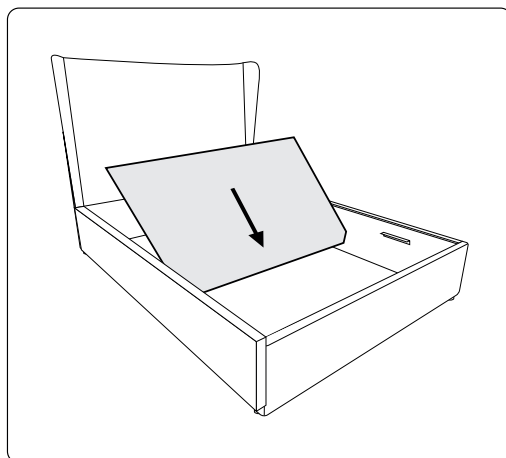

**8.** Take the two inner frames, place them next to each other on the floor.

The part with the holes on the sides are the head parts.

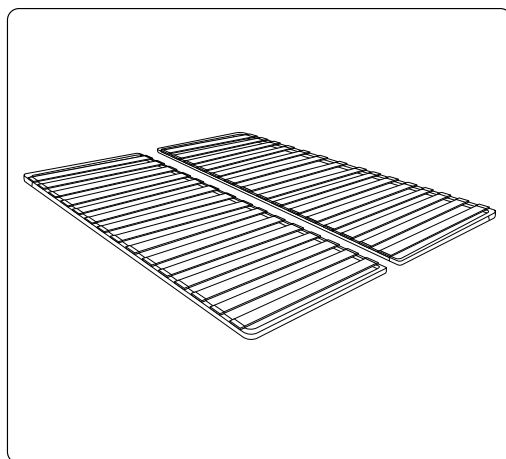

**9.** Join the two slatted frames with the brackets in both ends. Push the joining brackets over the center both ends. Line up the holes on the joining bracket to the holes on the frames.

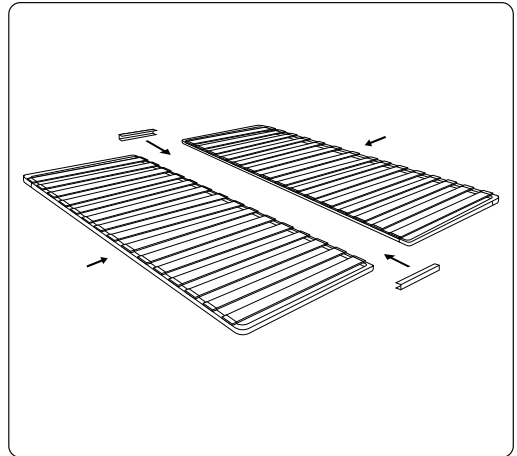

**10.** Slot the M6 x 55 bolts through the holes and fix slightly with the domed head M6 nuts. Do it at head and foot end of frame. Then adjust the frames next one another if necessary. Tighten the bolts and nuts.

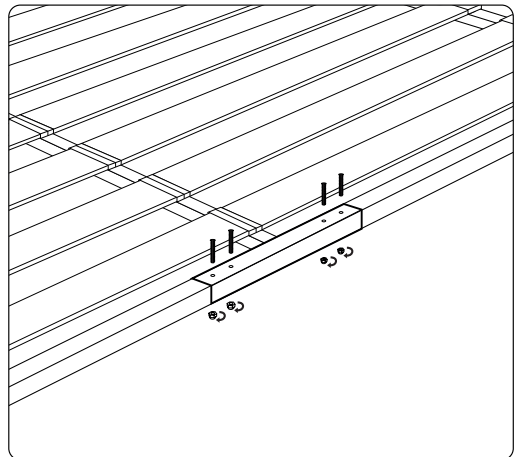

**11.** Place the mattress stoppers to head end.

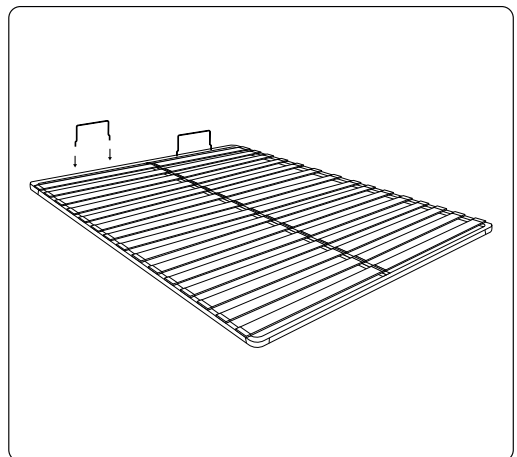



**12.** Carefully place the inner frames on the bed. Again, it takes two persons to do it safely.



**13.** Align the holes on the frame with the holes on the hinge and pass the four M6 x 50 bolts through washers provided and then into the holes each side of the frame. Place a M6 nut onto each of the M6 bolts and tighten with fingers then then using the Allen key provided, fully tighten the bolts.

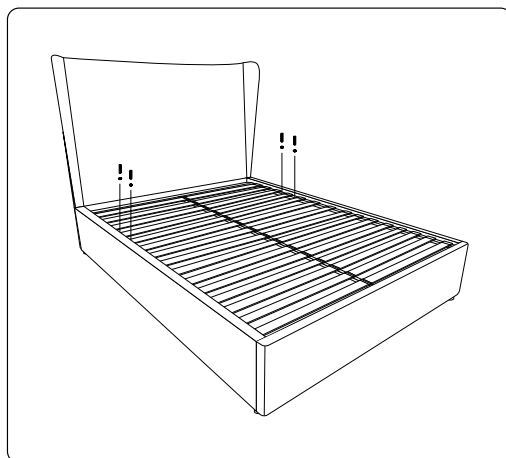

**14.** Add pistons to the both sides of bed. While one person holds the slatted frame up, the second person must fit the piston to the hinge. Connect and fix the pistons with the hinges. You need 2 pistons and 4 M8 nuts.

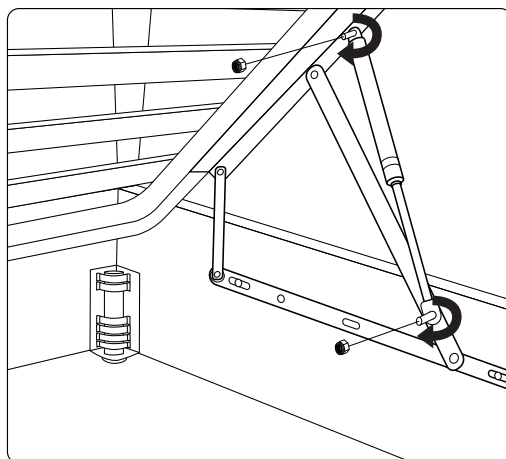



## CAUTION

Check the bolts on the ottoman action every few months to make sure that these are properly and firmly attached to its position.

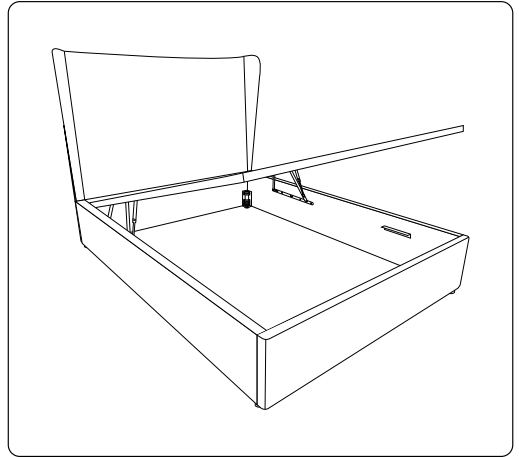

## CAUTION

Don't leave the storage bed in closed position without weight (mattress) on top of it. Especially don't leave it unattended in case you have children. The frame can spring upwards quickly and suddenly without the weight of the mattress and cause injuries.



**15.** Place the mattress to its position. One person should hold down securely the slatted section when other is placing the mattress.

