

TEMPUR ARC™ Bed range

ASSEMBLY GUIDE

Contents

TEMPUR ARC™ Outer frames assembly guide	4
Product exceptions: Luxury headboard	7
TEMPUR ARC™ Inner frames assembly guides	
TEMPUR ARC™ Static disc inner frames assembly guide	13
TEMPUR ARC™ Adjustable disc inner frames assembly guide	20
TEMPUR ARC™ Storage mesh assembly guide	37
TEMPUR ARC™ Ottoman inner frame(s) assembly guide	44
TEMPUR ARC™ Storage disc inner frames assembly guide	50
TEMPUR ARC™ Support leg assembly guide	61

Welcome to TEMPUR®

Thank you for choosing a TEMPUR® product.

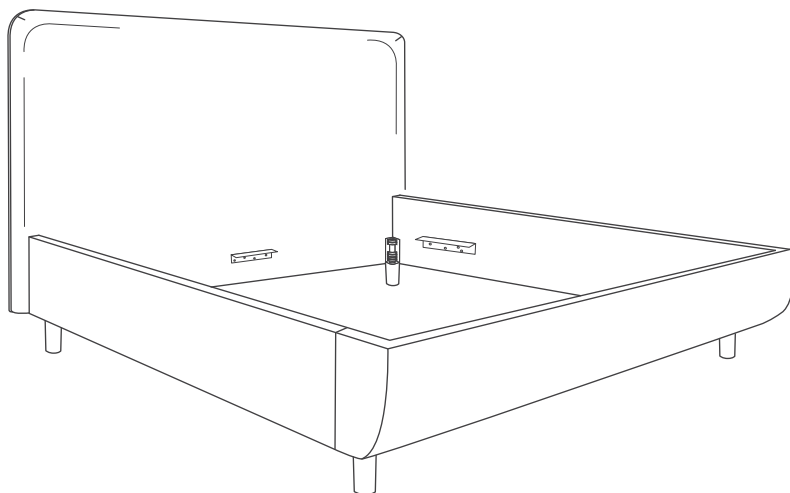

TEMPUR ARC™ Bed range

Outer frames assembly guide



CAUTION

The assembly instructions must be followed closely to install the bed system successfully, safely, and to minimize the risk of personal injuries and damage to the product.



Assemble the product with a minimum of two persons.



Open the packaging carefully, so as not to damage the product and its parts.
Dispose of the packaging safely and as sustainably as possible in your local area.

Component list

Check all components. All the means and tools required for product assembly come with the product:

1 x headboard

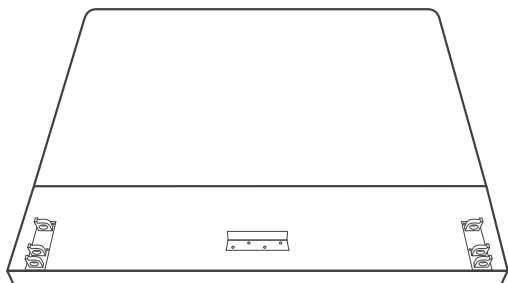

2 x side panels

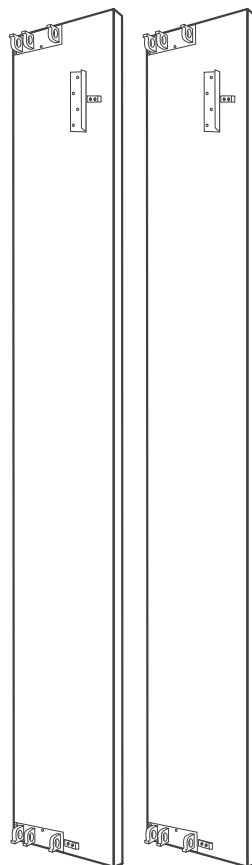

1 x foot-end panel

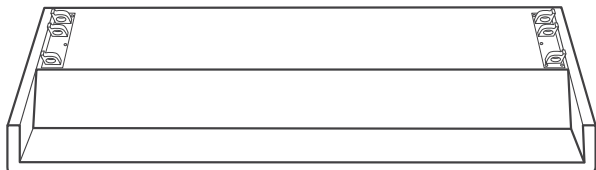

4 x cones; 4 x leg details; 4 x felt pads

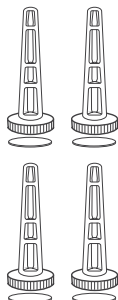
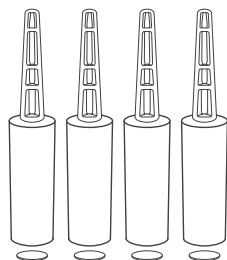

Products exceptions

TEMPUR® LUXURY headboard extra component

In case you have a TEMPUR® LUXURY headboard, there is an additional component, a headboard extra panel.

TEMPUR® LUXURY will be standing on the floor. The additional panel is attached on the headboard in the factory. It is moving on rails up and down into the right position according to the legs height.

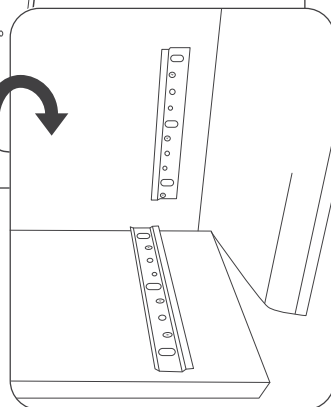
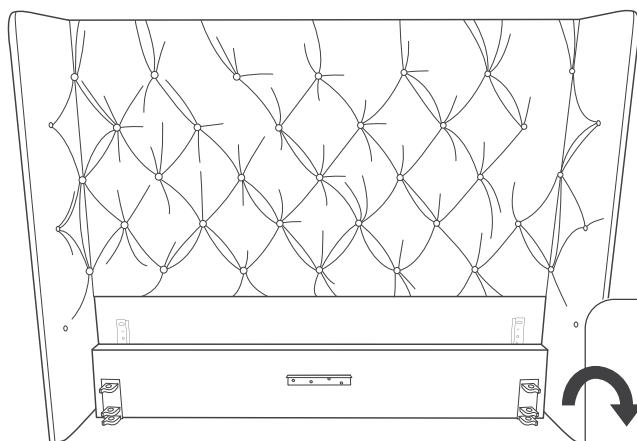

Assembly steps

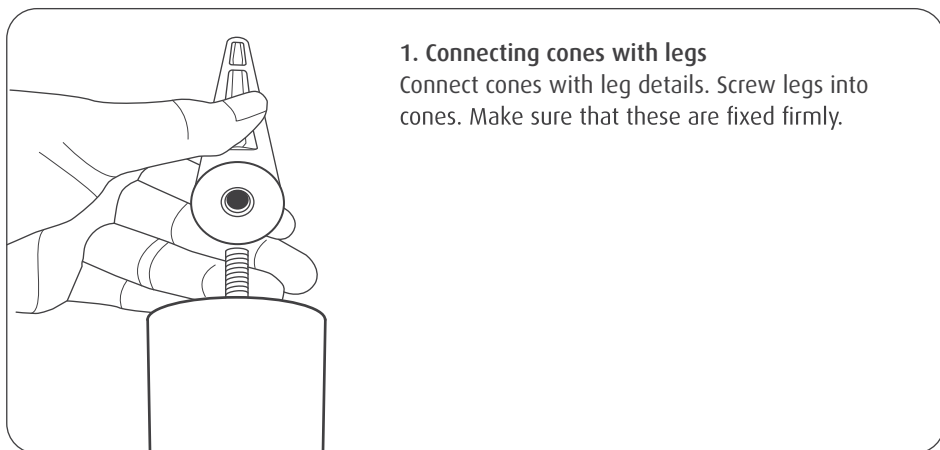

2. Follow icons on the corner connectors

Follow the head and feet graphic icons on the corner connectors. You need to connect the corners with matching icons on them, feet with feet and head with head. Follow the direction of the icons; they need to be upright as shown in the drawing.

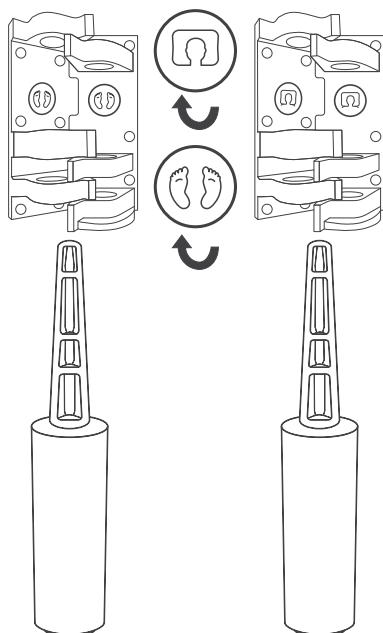
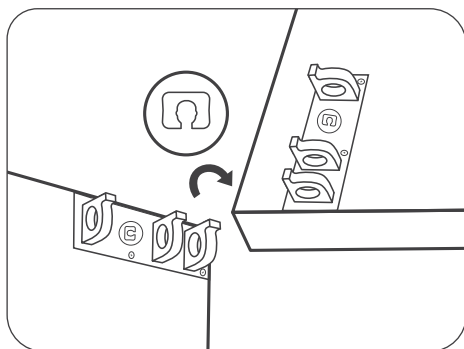

3. Organizing the bed parts

Lay all outer frame parts on the floor, connectors facing upside.

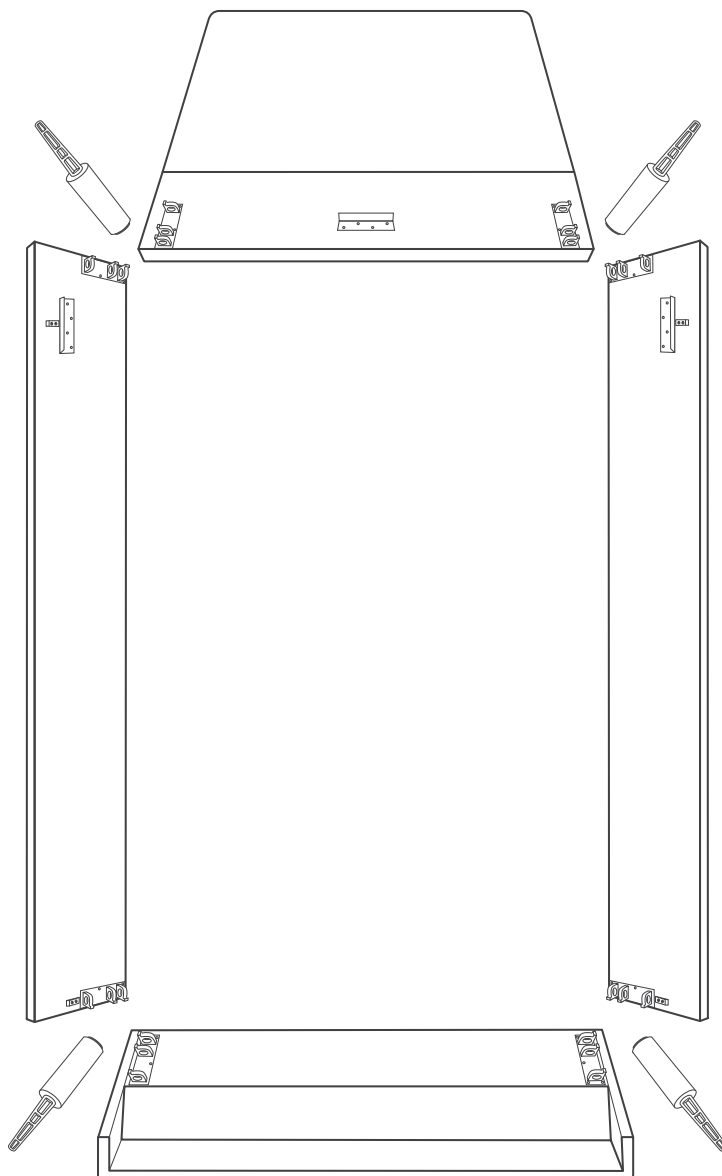

4. Connecting one side panel with headboard

Place one side panel into the headboard corner connector. Fix the panel by placing one leg into the corner connector. Push the leg, no need to twist the legs. When the bed frame will be lifted into its upright position afterwards, these will be fixed in firmly.



CAUTION

Be careful not to trap your fingers between the corner fingers joint nor between the leg cone and the corner connector while attaching the leg.

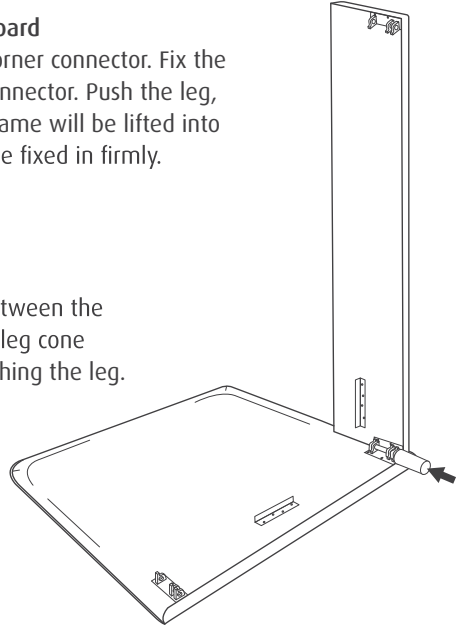

5. Connecting second side panel with headboard

Connect second side panel with the headboard corner connector and fix it with another leg.

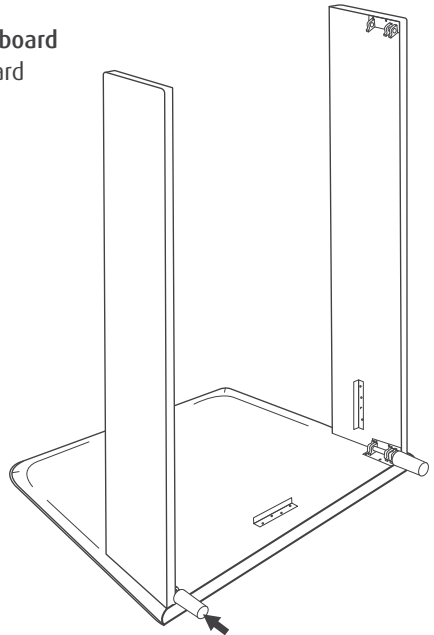

6. Turning bed to horizontal position

One person is standing on one side of the bed frame by the head-end and another one the opposite side. Hold with one hand the headboard and with other hand the side panel, follow the arrows on the drawing for hand positions. Turn the bed to its horizontal position. If there is little space in the room, you can lift the head-end while turning the frame around, in this way it saves space.

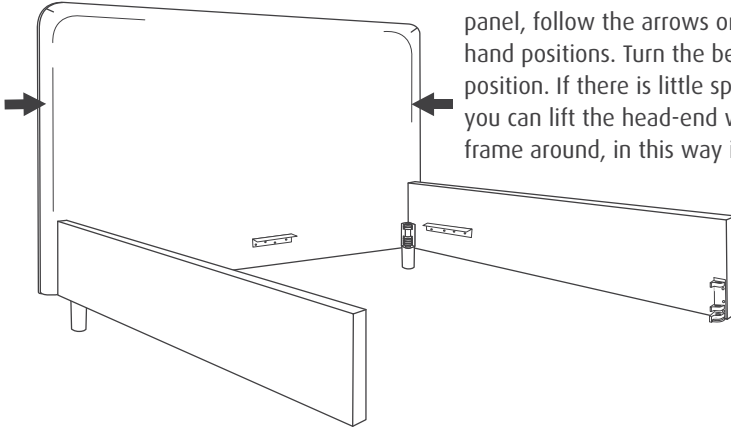

7. Adding foot-end panel

One person is standing by one foot-end corner and the other person is standing by the opposite corner, shown with arrows on the drawing. Add the foot-end by connecting both foot-end panel corners into the side panel corner connectors. To do it smoothly, do it in one rhythm and simultaneously.

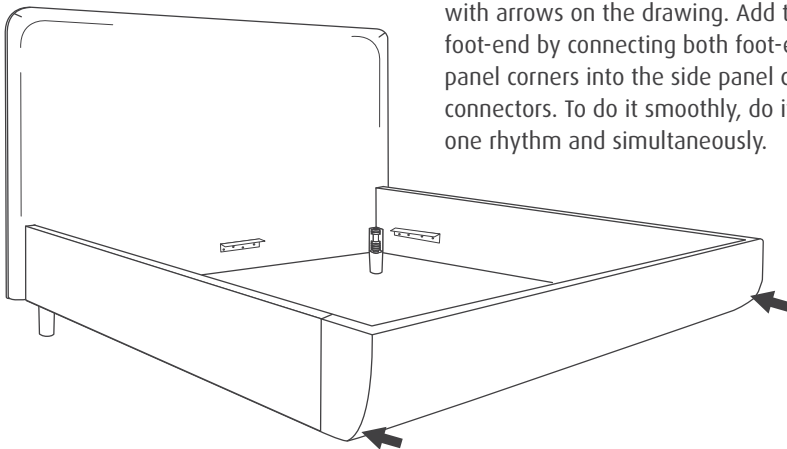

8. Fixing the foot-end with legs

One person is by one foot-end corner and another one in the opposite corner, shown with arrows on the drawing. Fix the foot-end panel by placing legs in each corner connector and push them. No need to twist, the weight of the construction of the bed will fix the legs to the end position. To make sure that the legs are fixed firmly, you can lift the bed from the front and back corners slightly, not more than up to 10 cm, and let it fall to the floor under its weight.



CAUTION

While installing, keep your feet a safe distance away from the bed frame.

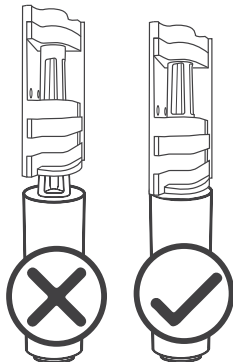
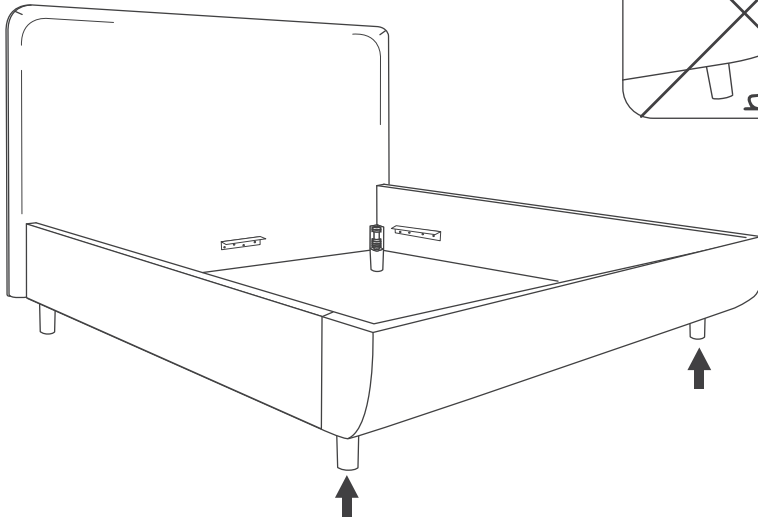
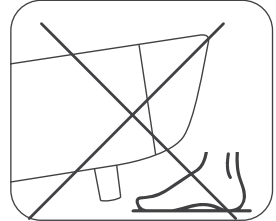

CAUTION

Make sure that the foot cone is completely inside the corner connector.

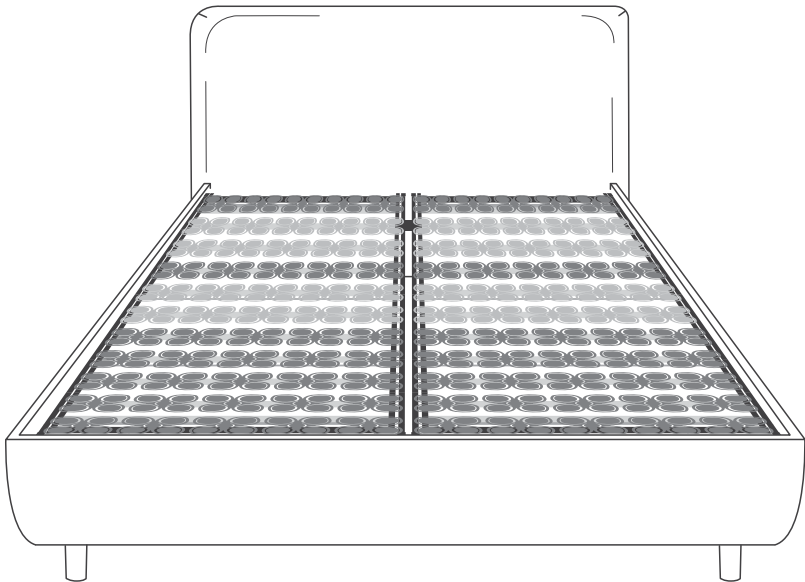
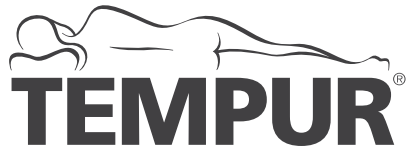

TEMPUR ARC™ Static Disc

Static disc inner frames assembly guide



CAUTION

The assembly instructions must be followed closely to install the bed system successfully, safely, and to minimize the risk of personal injuries and damage to the product.



Assemble the product with a minimum of two persons.



Open the packaging carefully, so as not to damage the product and its parts.
Dispose of the packaging safely and as sustainably as possible in your local area.

Components

Follow the direction of the frame; you have light grey discs at the head-end.

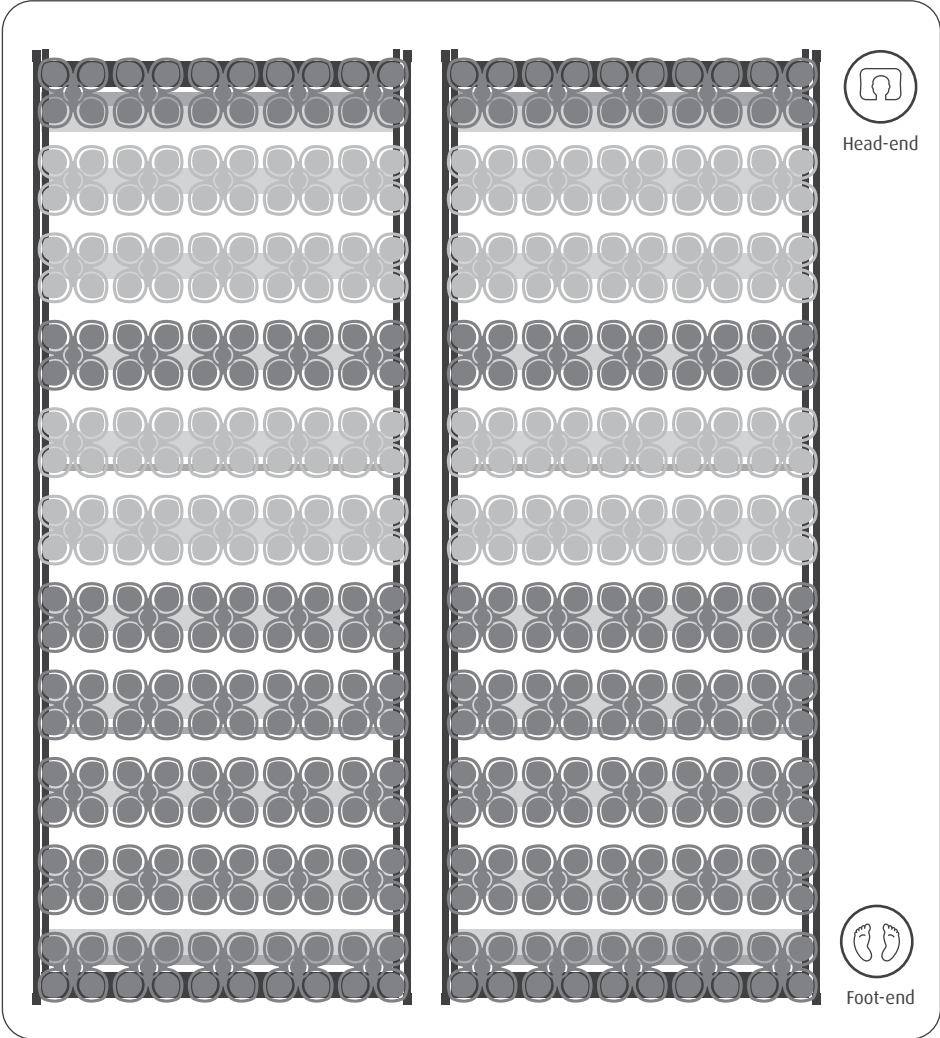

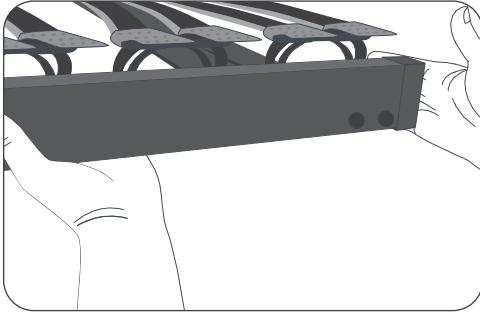

CAUTION

Lift and carry the frame with two people by holding it from the bottom support frames.

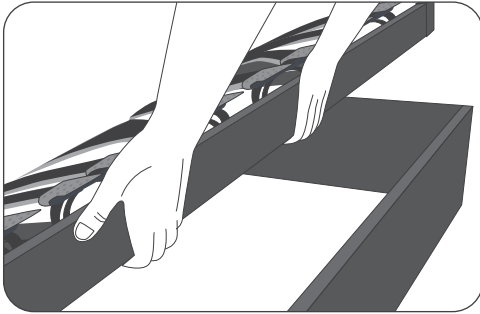

WARNING

While mounting the frames, be careful your fingers are not trapped between the outer and inner frame.

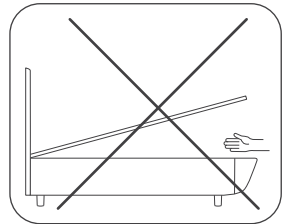

CAUTION

Be aware not to carry the frame only holding it from the middle of the slats or discs, these may come off or be damaged.

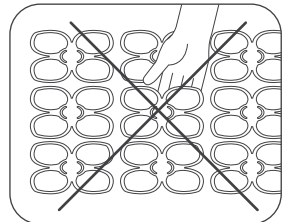

Double static disc inner frames placement

Take one frame with two people and turn it sideways. One person lifts the frame from the head-end and the other from the foot-end. Hold the frame from the longer side support frame. Place the frame sideways (inner side facing downwards) inside the outer frame. Install the frame head-end onto the headboard metal angle first and then the foot-end onto the bed foot-end. Drop the frame slowly sideways into a horizontal position, at the same time you need to lift the head-end so the discs do not to break.

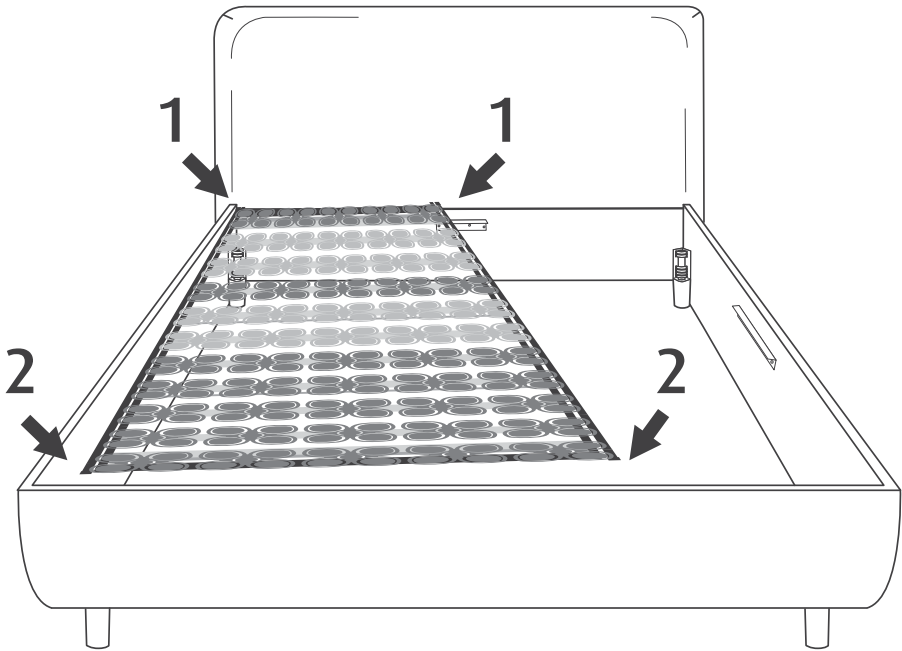

Add another frame the same way.

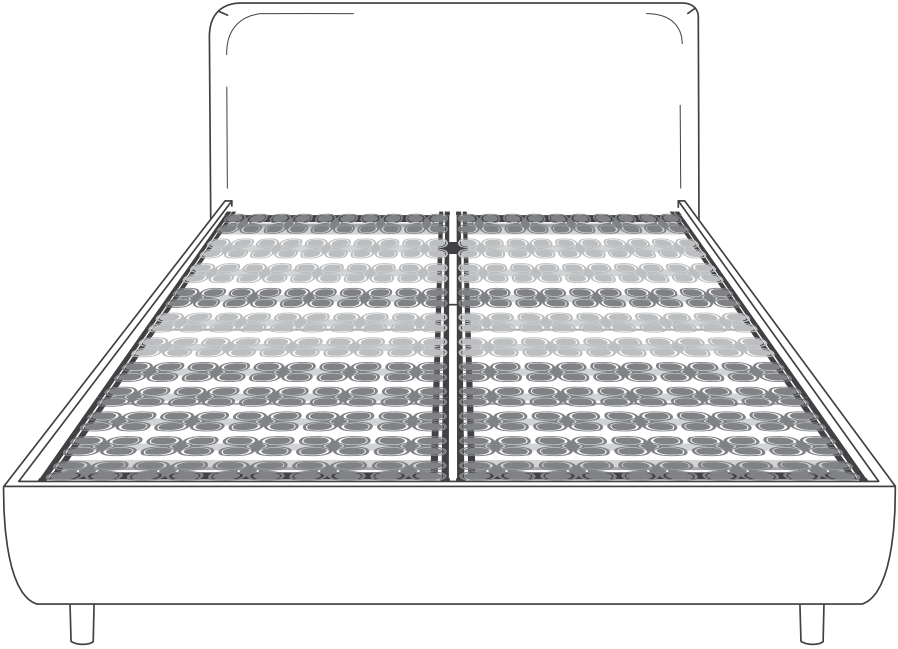

Discs are with different tensions, light grey coloured discs are softer and dark grey coloured are harder. You can change the disc positions according to your preferences.

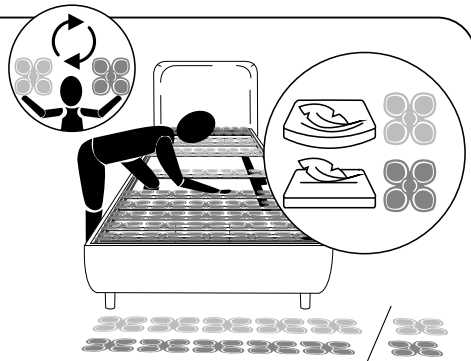

Mattress placement

Place the mattress in position with two people. Follow the TEMPUR® brand, which should be placed in the front left corner of the bed.

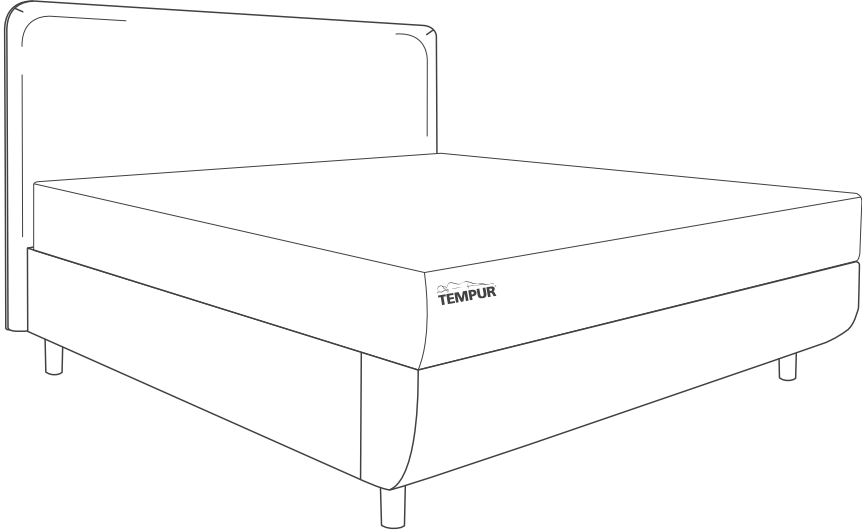

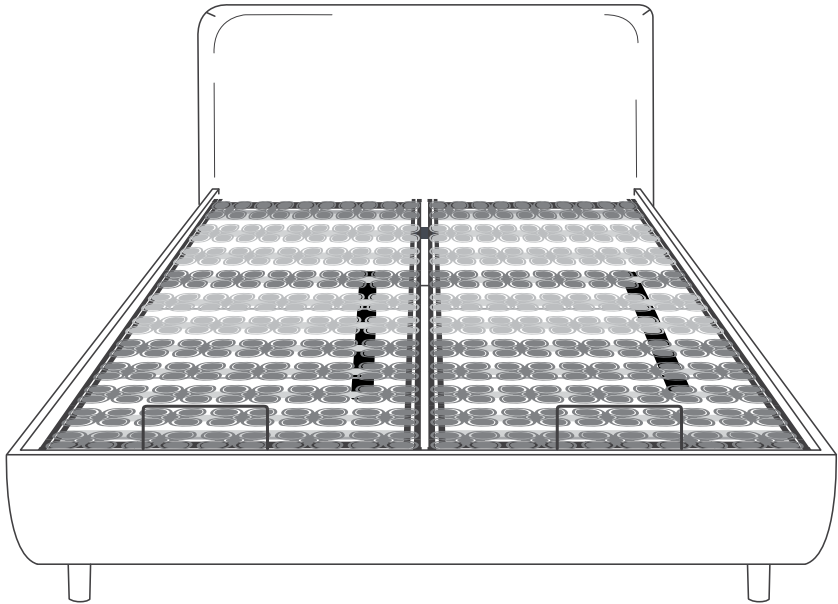

TEMPUR ARC™ Adjustable Disc

Adjustable disc inner frames assembly guide



CAUTION

The assembly instructions must be followed closely to install the bed system successfully, safely, and to minimize the risk of personal injuries and damage to the product.



Assemble the product with a minimum of two persons.



Open the packaging carefully, so as not to damage the product and its parts.
Dispose of the packaging safely and as sustainably as possible in your local area.

Components

Follow the direction of the frame, you have light grey discs on the head-end side of the frame.

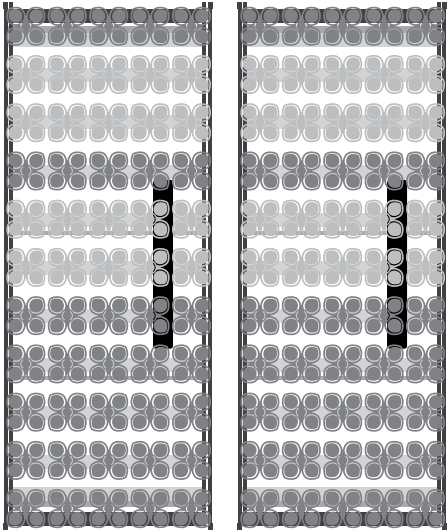

Head-end

Foot-end

2 x Premium remote control

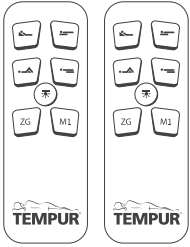

4 x cable
2 x adapter

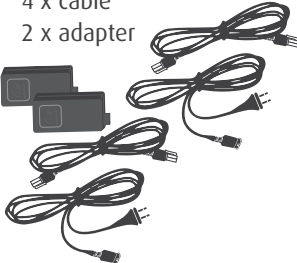

2 x mattress bar



Removing transit ties

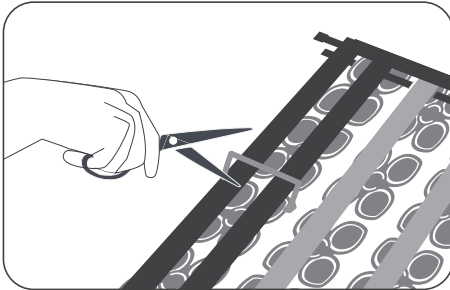

Remove the transit ties from both sides of the frame by cutting.

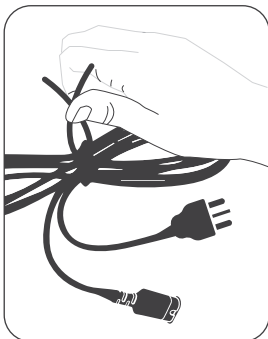
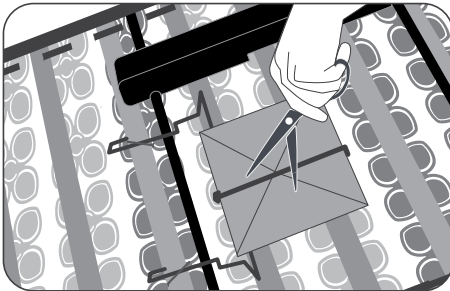

Remove the fastening tie from the cable.

Premium motor

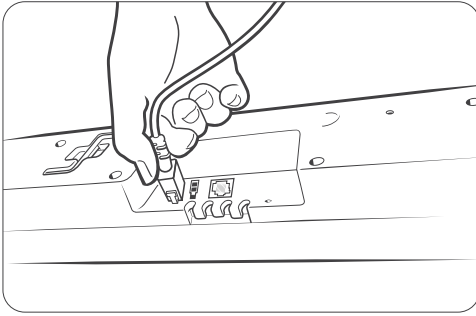

Connect the correct plug end into the motor mains and insert the other end into the adapter.

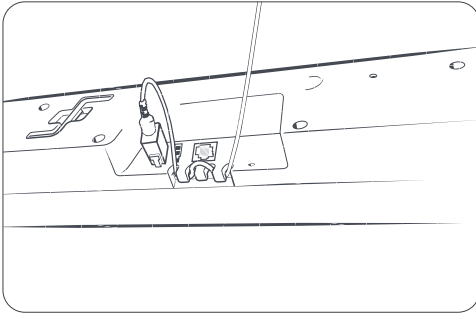

Lead the cable around the middle relief. By using the relief, you avoid the mains cable plug being pulled out of the motor and a potential malfunction.

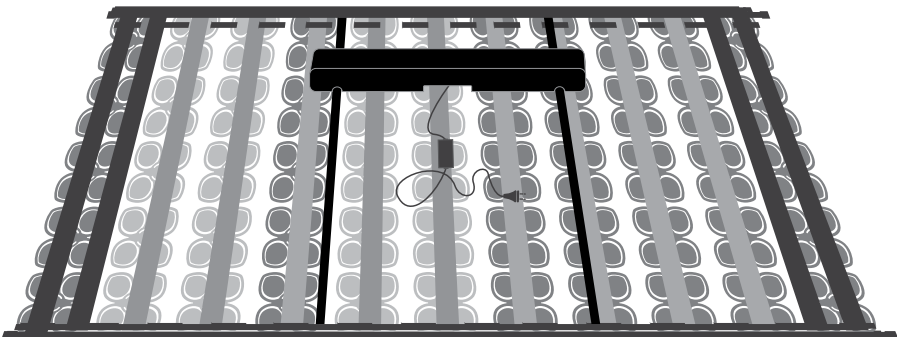
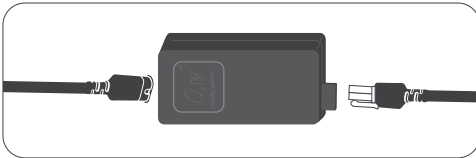

Mattress bar installation

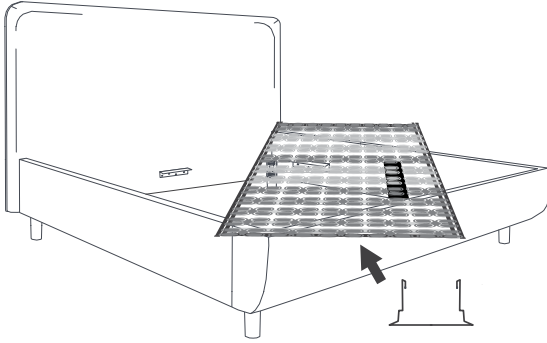

The mattress bar needs to be attached on the support frame, under slat units, at the foot-end side.

Remove first slat unit with discs by pulling it out. Firstly, pull out slat unit one end and then the other end. Place and pull the mattress stopper to its position on the support frame. Install the slat unit back to its place.

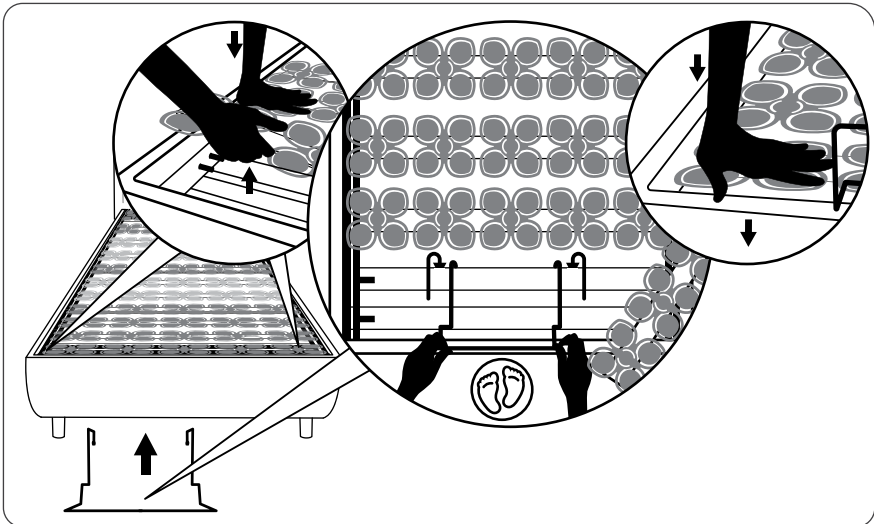

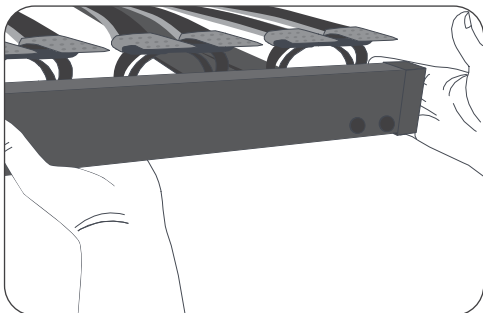

CAUTION

Lift and carry the frame with two people by holding it from the bottom support frames.

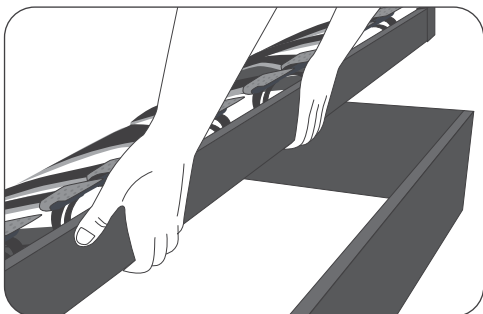

WARNING

While mounting the frames, be careful your fingers are not trapped between the outer and inner frame.

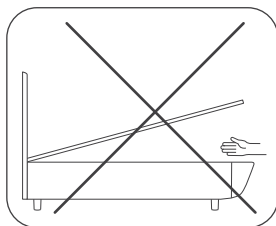

CAUTION

Be aware not to carry the frame only holding it from the middle of the slats or discs, these may come off or be damaged.

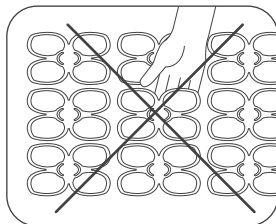

Double adjustable inner frames placement

Installing first frame:

Both persons should hold the frame from its longer opposite sides.

Hold from the bottom non-moving part of the frame and lift the frame horizontally.

One person stands by the bed outer frame and the other steps inside the bed base.

Place the frame head-end onto the corners and headboard metal angle.

Once this part is in place, one person can move to the foot-end and hold the inner frame from the mattress bar.

When one person is firmly holding the mattress bar, the other person can now slowly let go of the frame.

Lastly the person holding from the mattress bar should now slowly drop the frame end onto the bed foot-end.

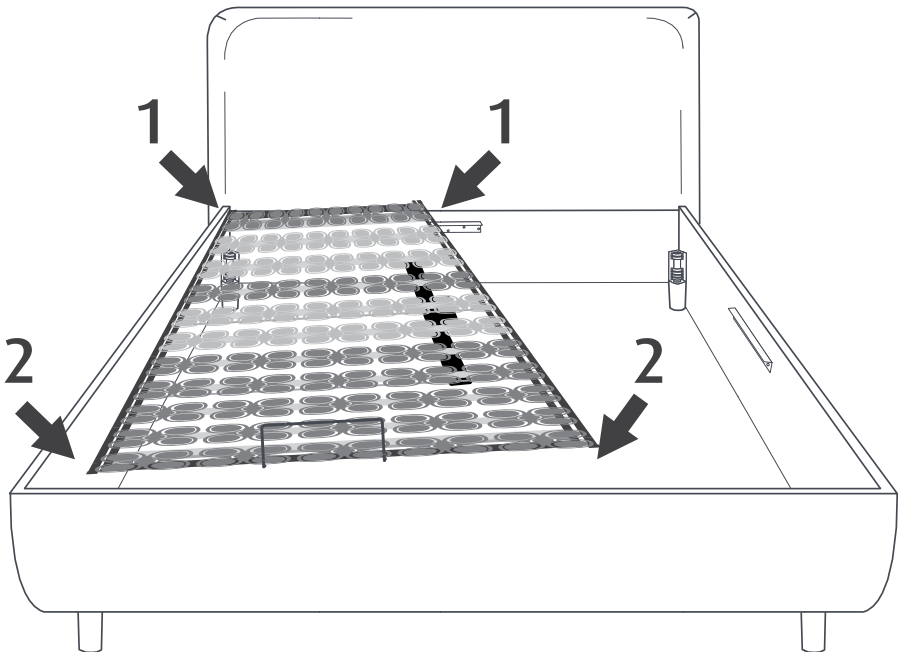

Installing second frame:

Lift the frame sideways. The longer side, which will be inner side in the bed base, needs to be facing downwards.

Hold from opposite frame ends from non-moving part of the frame.

The person standing on the head-end side steps into the bed base.

Place the inner frame head-end onto the headboard metal angle, and the other end onto the bed foot-end. Raise and slide slightly the frame head-end inner corner for stabilization.

Now the person inside the bed base can step out of the frame, still holding onto the frame. After stepping out of the bed base, drop and slide slowly the frame head-end into place.

When the head-end of the frame is almost in place, the person at the foot-end grabs the mattress bar. Now the person at the head-end can let go of the frame. The person on the foot-end holds onto the mattress bar, and holds the foot-end of the frame up and slowly drops it onto the bed base foot-end.

Discs are with different softnesses, light grey coloured discs are softer and dark grey coloured are harder. You can change the disc positions according to your preferences.

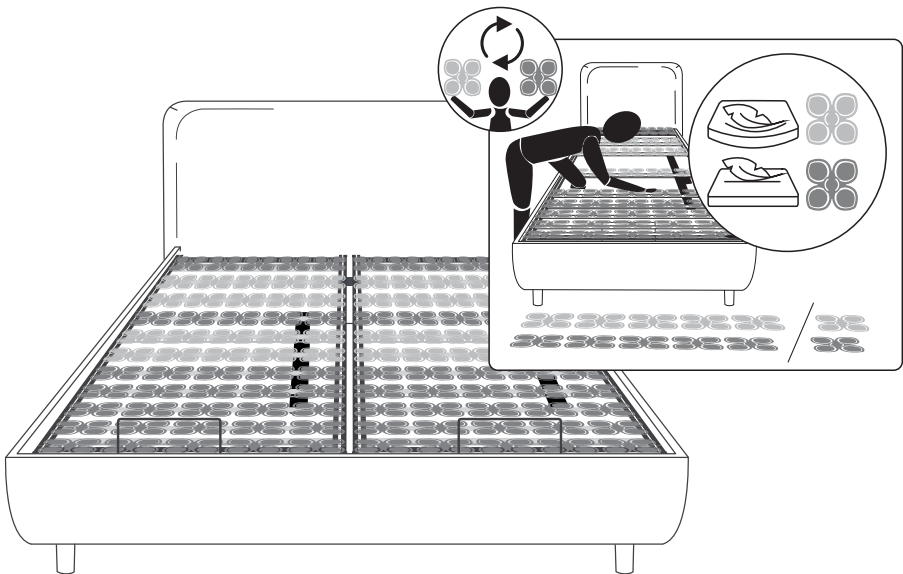

Pairing two motors and two remotes - Frames working in a separate mode

1. Plug first motor cable into the power socket.
2. The motor light will start to blink at a steady pace and now you have 3 minutes for pairing.
3. Press and hold down (minimum for 4 seconds) the top two remote buttons on the first remote for pairing.
4. Wait until you see one long light flash on the motor light (light stays on for about 1,5 sec). This is the signal for successful pairing of the first remote.
5. Press any button on the first remote. This step will end the pairing between the first motor and first remote (now in this stage, no other remote can be paired with the first motor instantly).
6. Plug second motor cable into the power socket.
7. The motor light on the second motor will start to blink at a steady pace and now you have 3 minutes for pairing.
8. Press and hold down (minimum for 4 seconds) the top two remote buttons on the second remote for pairing.
<9. Wait until you see one long light flash on the motor light (light stays on for about 1,5 sec). This is the signal for successful pairing of the second remote.10. Press any button on the second remote. This step will end the pairing between the second motor and second remote.

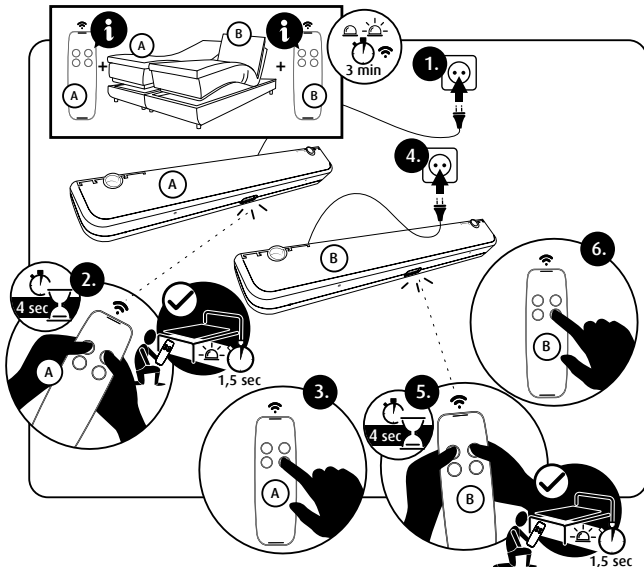

NB! While pairing second motor with second remote, do not use the first remote (do not press any buttons on it)

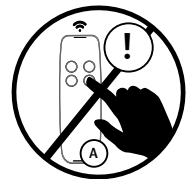

Pairing two motors and two remotes - Frames working in a parallel mode

1. Plug the cables of both motors into power sockets.
 2. Both motor lights will start to blink at a steady pace and now you have 3 minutes for pairing.
 3. Press and hold down (minimum for 4 seconds) the top two remote buttons on the first remote for pairing.
 4. Wait until you see one long light flash on both motors (light stays on for about ca 1,5 sec). This is the signal for successful pairing of the first remote.
- NB! Do not press any other buttons on the first remote, because if you do that the motor comes out of the pairing mode and you will be unable to pair another remote.
5. Press and hold down (minimum for 4 seconds) the top two remote buttons on the second remote for pairing.
 6. Wait until you have seen again one long light flash on both motors (light stays on for about 1,5 sec).
 7. Now you can check the remotes functioning by pushing any buttons. The frames should work simultaneously.

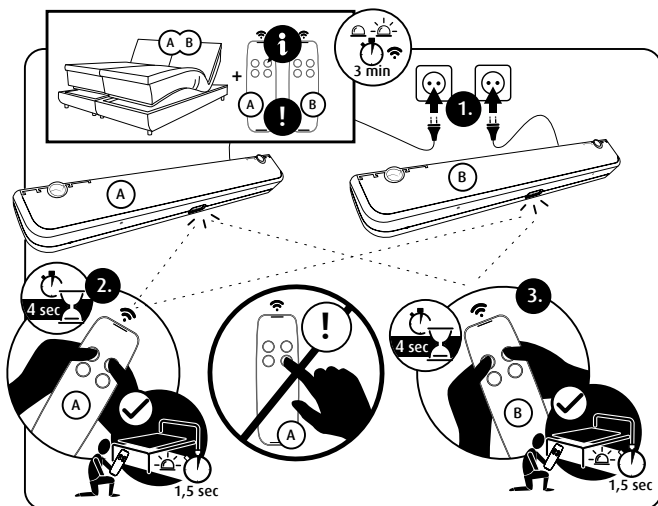

NB! Notice that you can use still one remote at once. Between using one and another remote you need to wait ca 5 seconds.

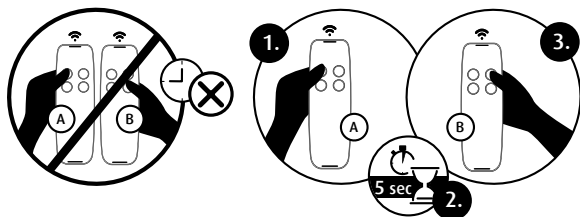

Pairing two motors and one remote - Frames working in a parallel mode

1. Plug the cables of both motors into power sockets.
2. Both motor lights will start to blink at a steady pace for 3 minutes and now you have 3 minutes for pairing.
3. Press and hold down (minimum for 4 seconds) the top two remote buttons on the remote for pairing.
4. Wait until you see one long light flash on both motors (light stays on for about 1,5 sec). This is the signal for successful pairing.
5. Check if the frames work simultaneously by pressing the remote buttons.

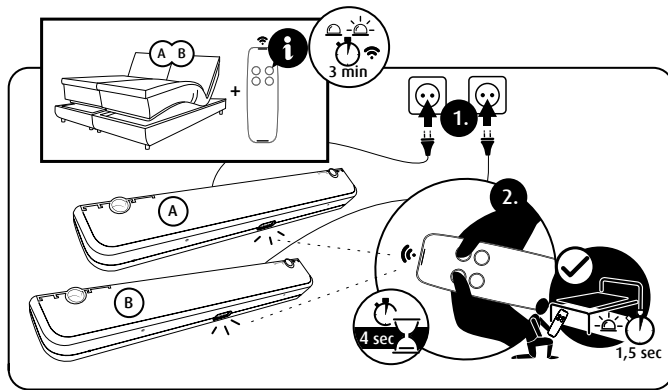

Restarting pairing

Version A

To restart pairing, unplug the motor cable(s) from the power socket and wait for 1 minute, then plug the cable(s) back in again. Now you are ready for pairing mode.

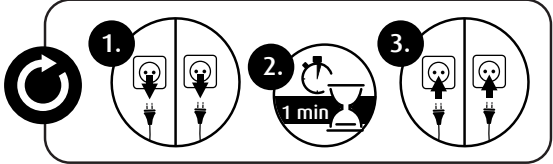

Version B

To do it faster, push the motor light(s) button on the remote(s) to light up and then take the motor cable(s) out from the power socket(s). Wait until the motor light(s) turns off. Then plug the motor cable(s) into the power socket(s) again and now you are ready for pairing.

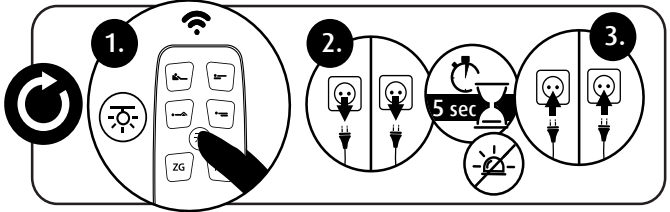

Premium remote functions

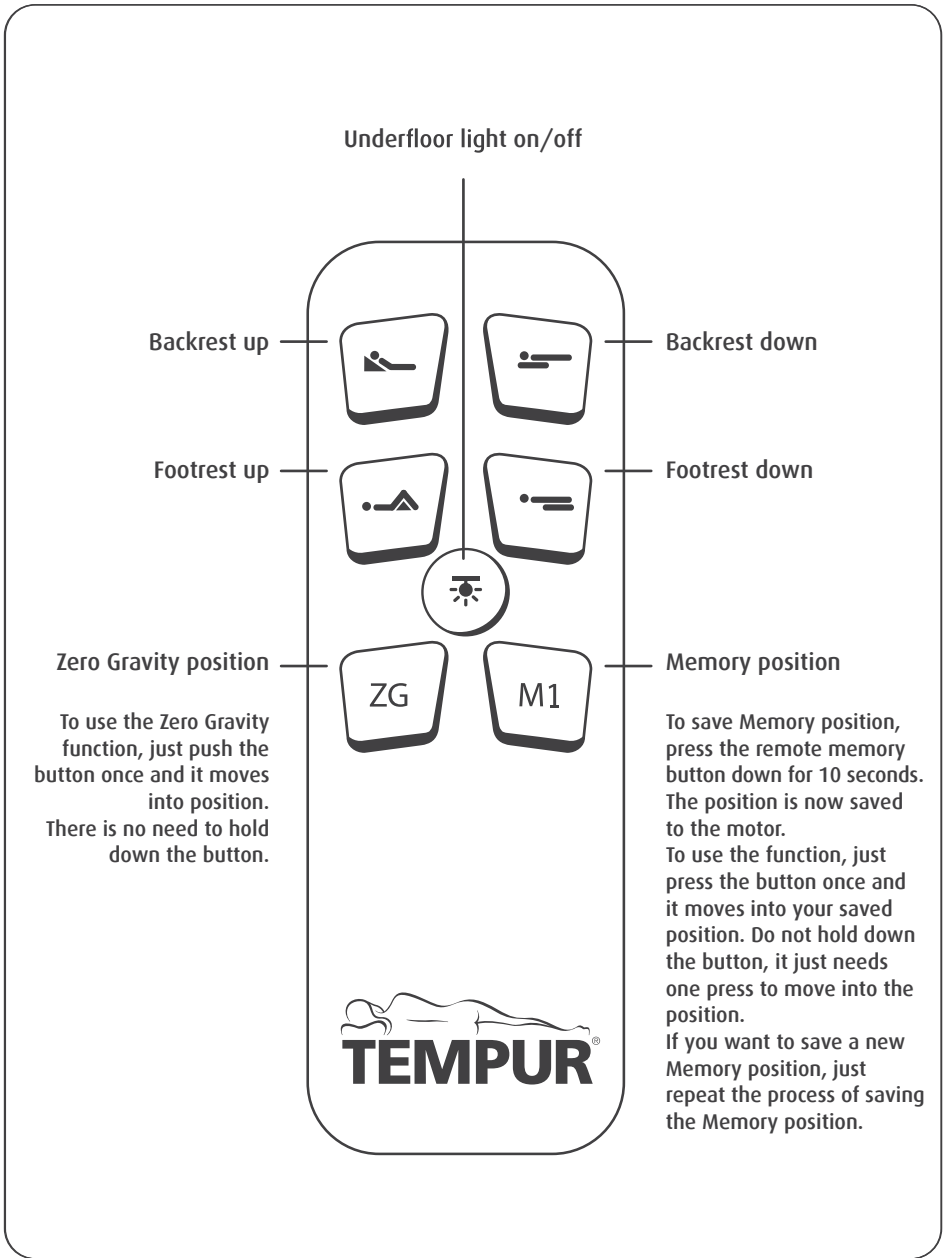

Mattress placement

Place the mattress in position with two people. Follow the TEMPUR® brand, which should be placed in the front left corner of the bed.

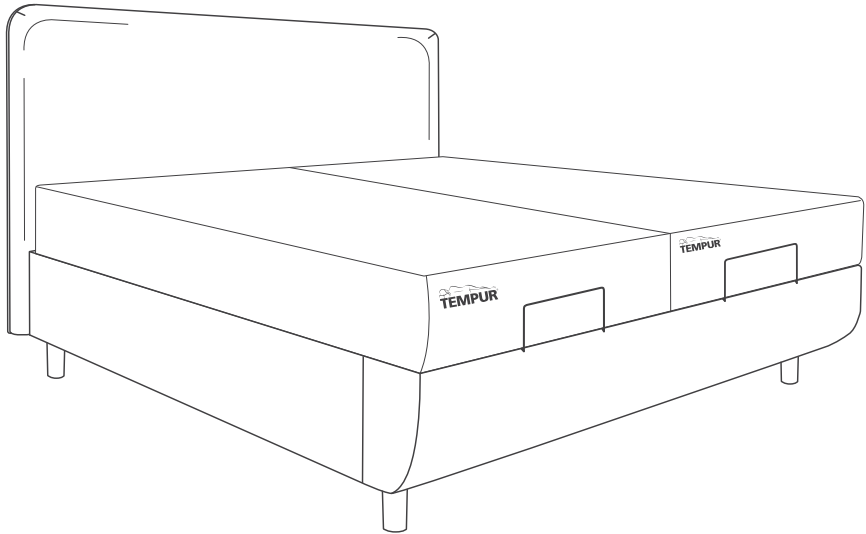

Emergency lowering

Emergency lowering is meant for lowering the bed if a power failure occurs and the bed needs to move into a horizontal position.

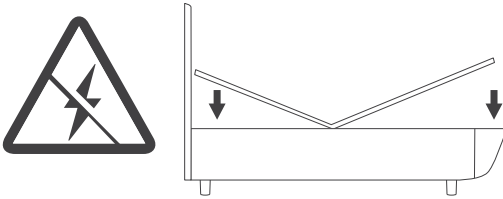

1. Disconnect the motor from the mains.
2. Remove the slats in the middle of the motor foot and head end side.
Remove the slats from the frame by clipping them out.

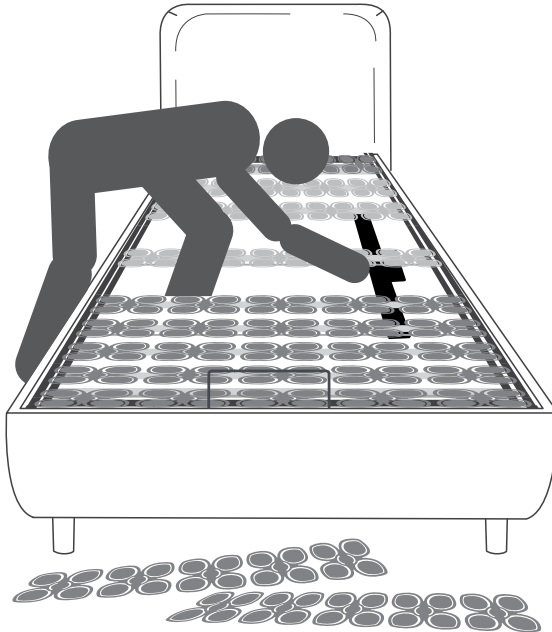

3. Take the hex key on the side of the motor, use something you have at home such as a pen to push the key out.

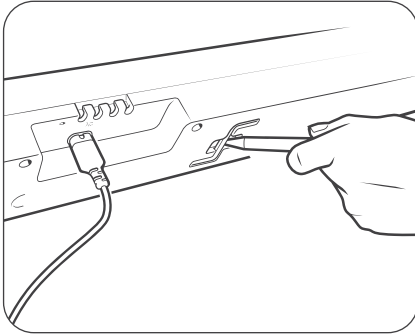

Do not use an electric screwdriver for lowering, use the hex key enclosed on the motor.

4. Underneath the motor, at the foot and head end side, are two gaps for mechanical lowering.
5. Place hex key in gap, one end at a time.
6. At the head end side, turn the hex key in an anticlockwise direction and at the foot end side turn the hex key clockwise.

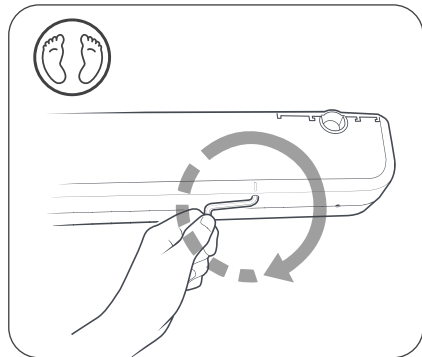
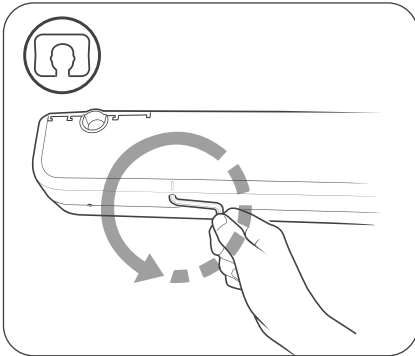

It is important to turn the key in the right direction. Turning the key in the wrong direction can damage the inner hex and make mechanical emergency lowering impossible.

7. Put the frame slats back.

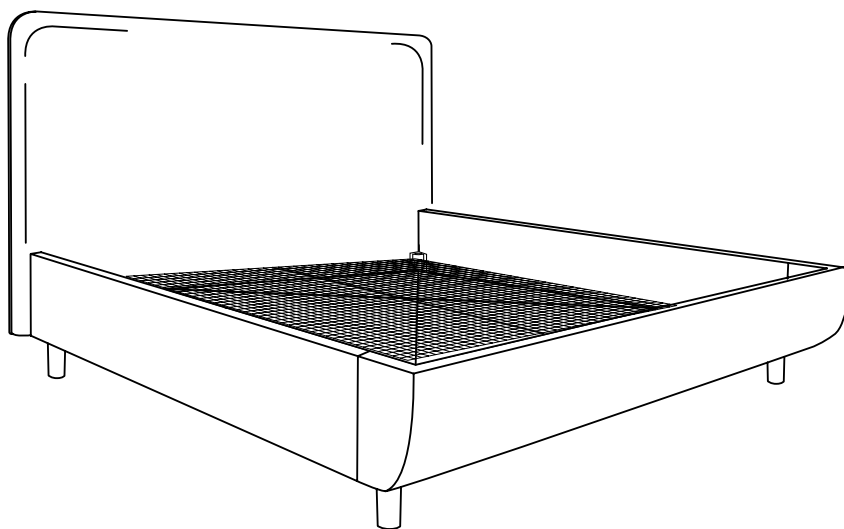

TEMPUR ARC™

Storage mesh net assembly guide



CAUTION

The assembly instructions must be followed closely to install the bed system successfully, safely and to minimize the risk of personal injuries and damage to the product.



Open the packaging carefully, so as not to damage the product and its parts. Dispose of the packaging safely and as sustainably as possible in your local area.



Assemble the product with two persons.



The recommended weight for storage mesh is up to 10 kg.



Please don't step on the mesh when installed.

Component list

1 x headboard

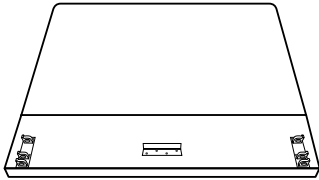

2 x side panels

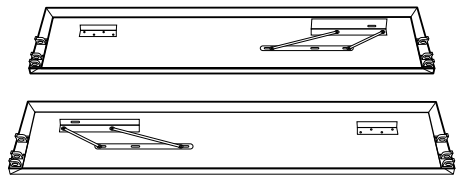

1 x foot end panel

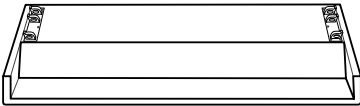

4 x cones; 4 x leg details; 4 x felt pads

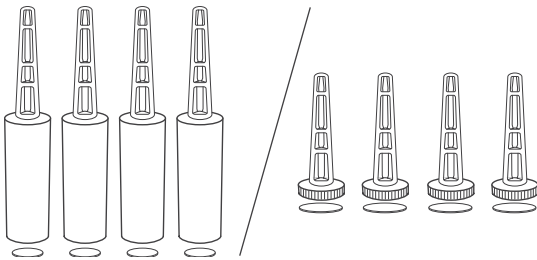

1 x storage mesh

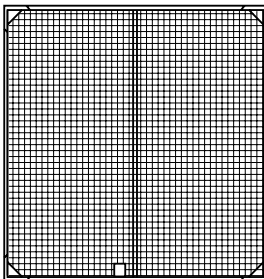

2 x strap



1. Lay all outer frame parts on the floor, connectors facing upside.

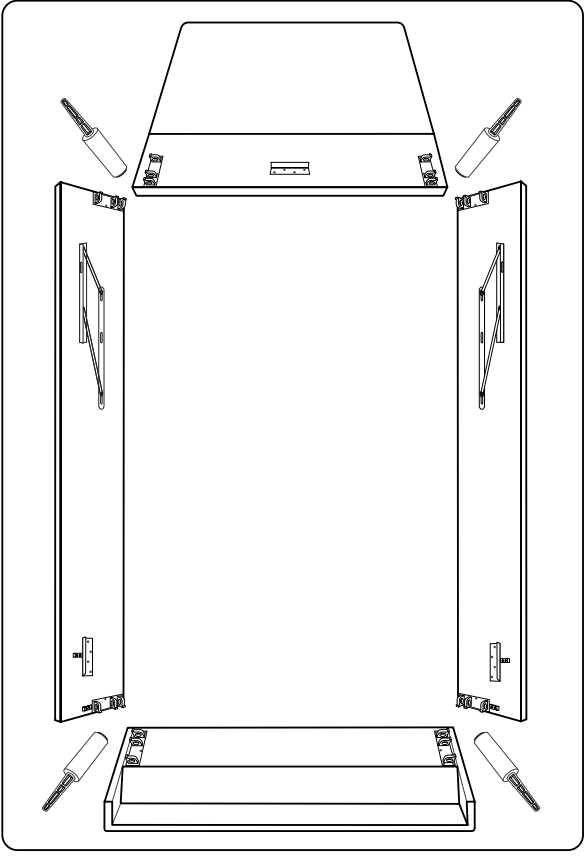

2. Connect cones with leg details. Screw legs into cones. Make sure that these are fixed firmly. Add felting pad.

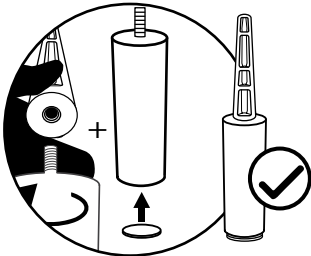

3. Place the straps diagonally on top of each other with the strap loops facing the corners.

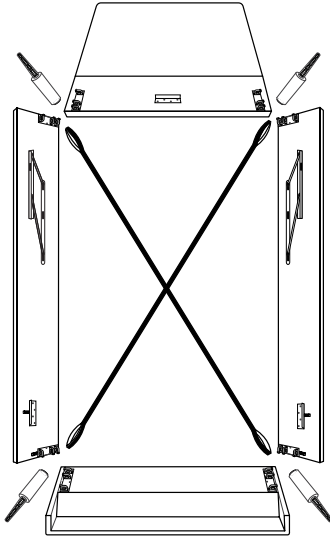

4. Place the storage mesh on top of the belts.

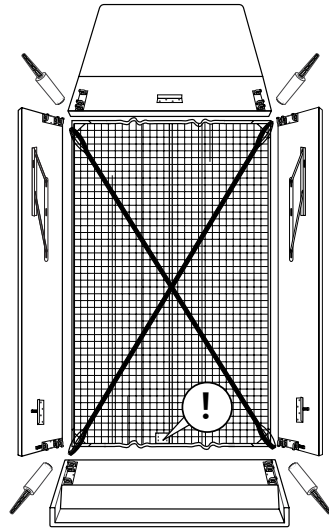

5. Place one side panel into the headboard corner connector. Fix the panel by placing one leg into the corner connector. Before fixing it firmly place the loops of strap and storage mesh on top of the leg cone. Push the leg, no need to twist the legs. When the bed frame will be lifted into its upright position afterwards, these will be fixed in firmly.



*Follow icons on the corner connectors
Follow the head and feet graphic icons on the corner connectors. You need to connect the corners with matching icons on them, feet with feet and head with head. Follow the direction of the icons; they need to be upright as shown in the drawing.

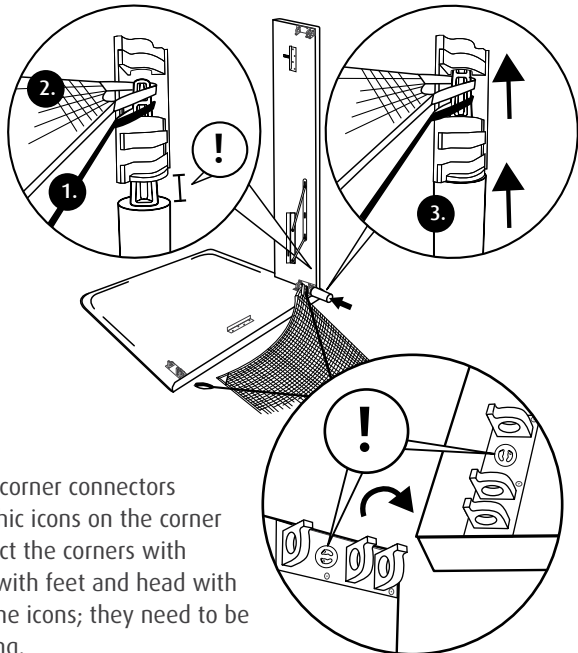

6. Connect second side panel with the headboard corner connector and fix it with another leg. Before fixing it firmly place the loops of strap and storage mesh on top of the leg cone.

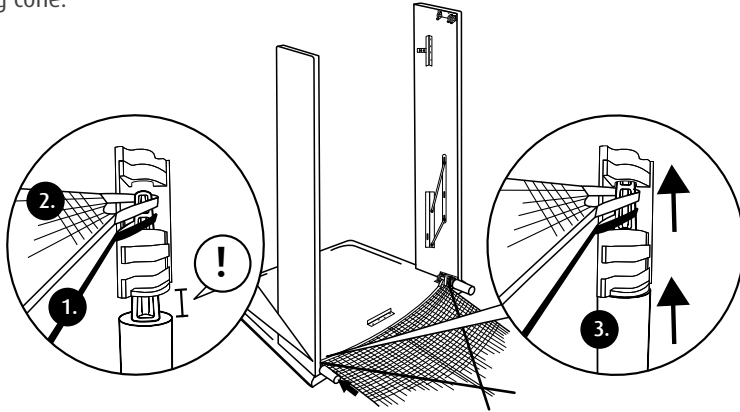

7. Turn the bed to its horizontal position. One person is standing on one side of the bed frame by the head-end and another one the opposite side. Hold with one hand the headboard and with other hand the side panel. If there is little space in the room, you can lift the head-end while turning the frame around, in this way it saves space.

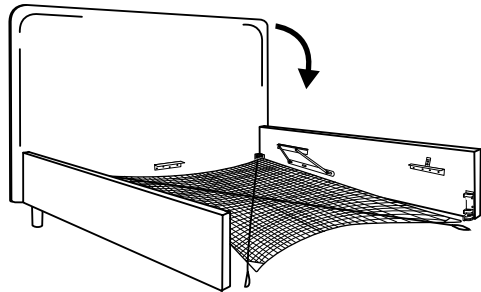

8. Add foot end panel. One person is standing by one foot-end corner and the other person is standing by the opposite corner. Add the foot-end by connecting both foot-end panel corners into the side panel corner connectors. To do it smoothly, do it in one rhythm and simultaneously. NB! Don't push the legs completely in yet, but leave some space between leg cone and the corner connector.

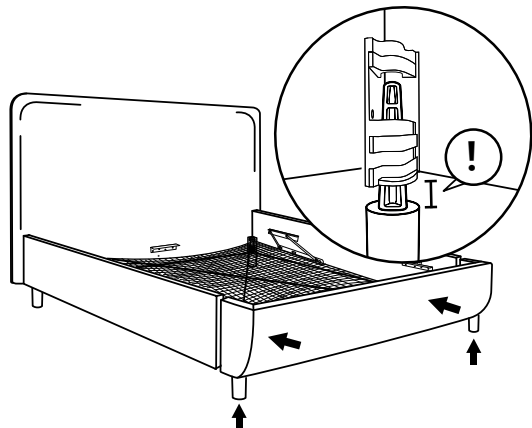

9. Place the straps and storage mesh loops into foot-end corners. One person is lifting the bed frame corner and other one places the loops inside corner connector on the top of the leg cone.

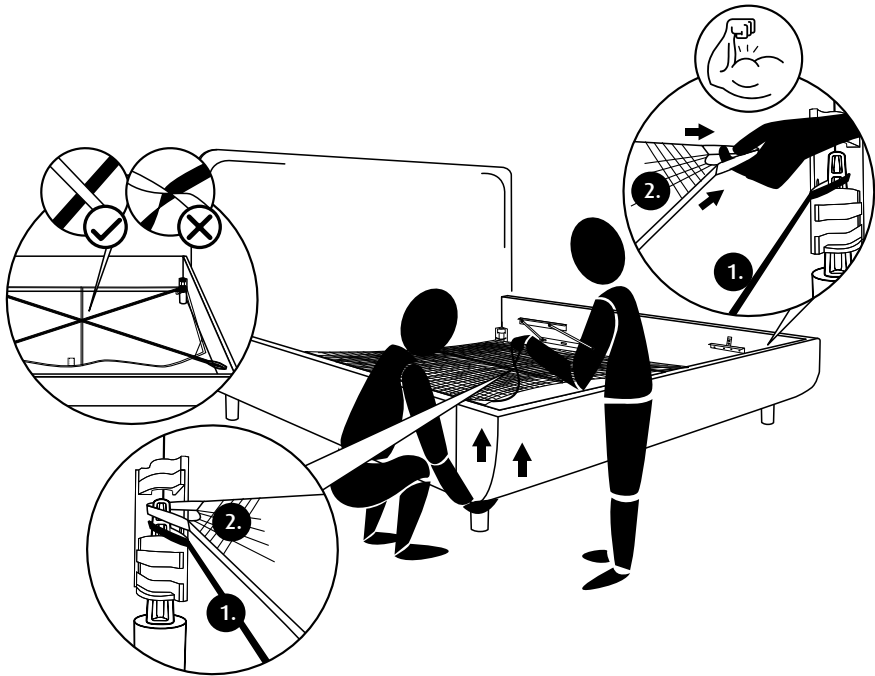

Finally make sure that all the legs are fixed firmly.

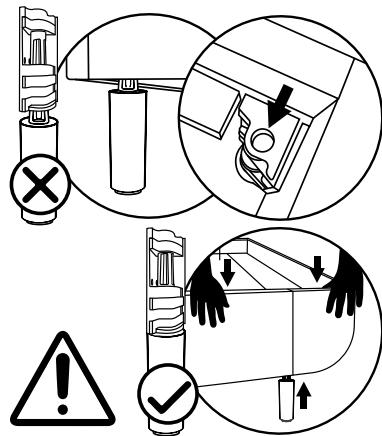

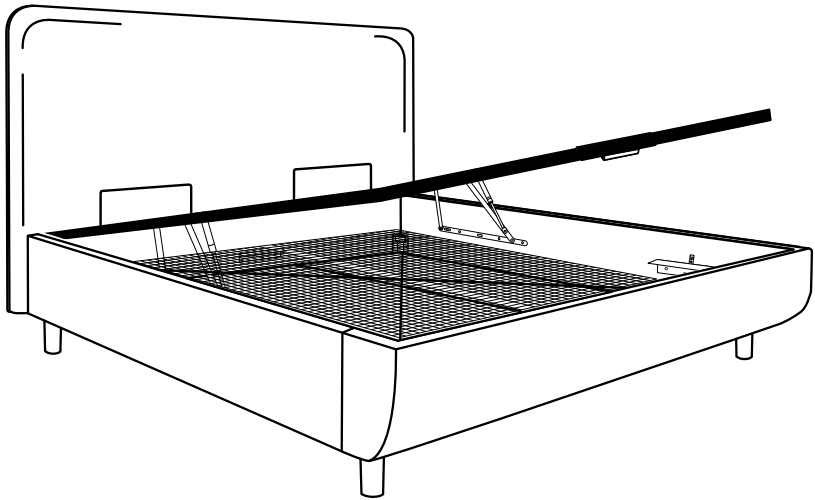

TEMPUR ARC™

Ottoman inner frame(s) assembly guide



CAUTION

The assembly instructions must be followed closely to install the bed system successfully, safely and to minimize the risk of personal injuries and damage to the product.



Assemble the product with two persons.

Component list

1 x or 2 x inner frames
(depending on the frame)

Components to join two inner frames

(incase you have two inner frames)

<p>3 x M6 70 mm bolts</p>	<p>3 x M6 nuts</p>	<p>1 x M6 spanner</p>	<p>1 x M6 Allen key</p>
---------------------------	--------------------	-----------------------	-------------------------

Components to prepare inner frame(s) for placement into bed base

<p>2 x joining brackets</p>	<p>1 x handle</p>	<p>8 x M6 60 mm bolts</p>	
<p>8 x M6 nuts</p>	<p>1 x M6 spanner</p>	<p>1 x M6 Allen key</p>	<p>1 x or 2 x mattress bar(s) (depending on the frame)</p>

Components to join hinges with the frames

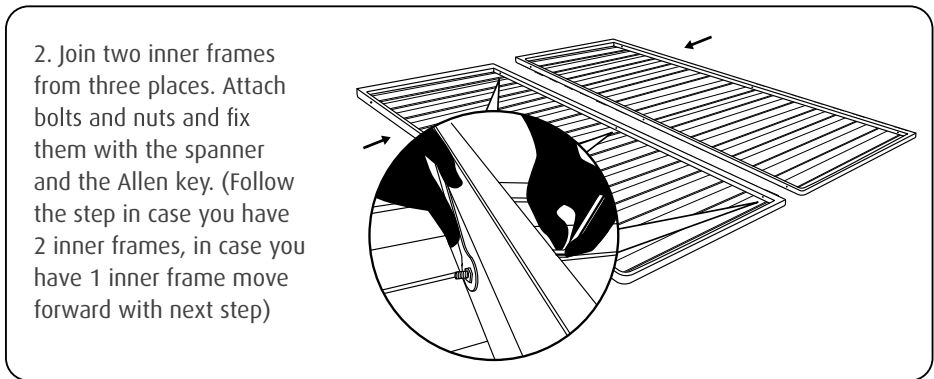
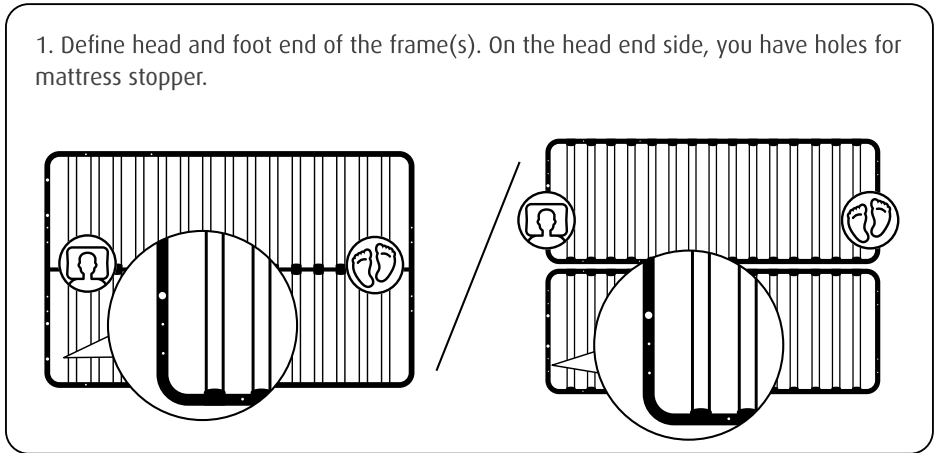
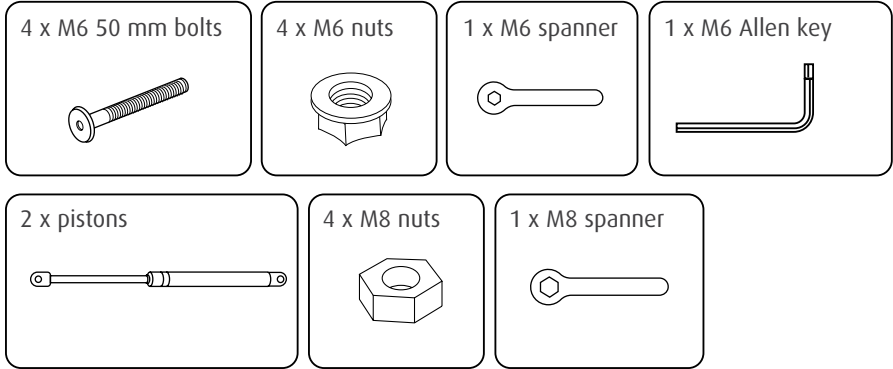

3. Slot the M6 x 60 mm bolts through the holes and fix slightly with the M6 nuts. Do it at both ends of the frame. At the foot end side add the handle on top of the bracket. Tighten the bolts and nuts with the M6 spanner and Allen key.

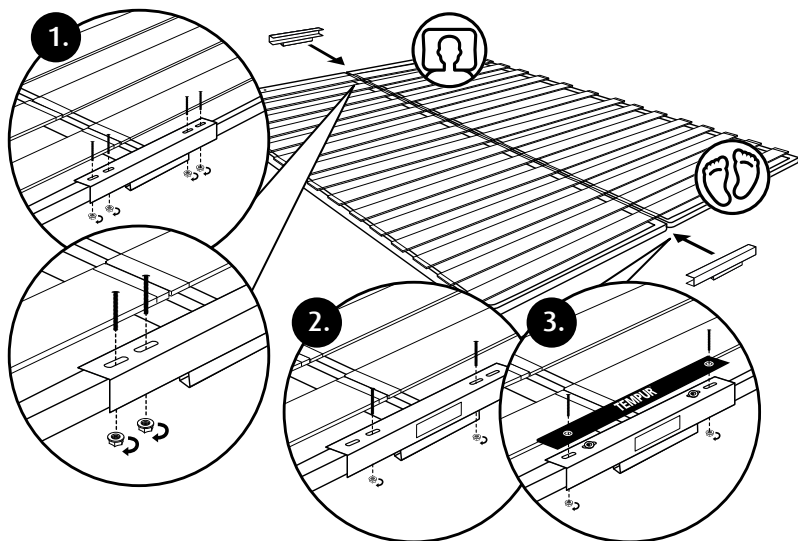

4. Place the mattress stoppers into the holes at the head-end.

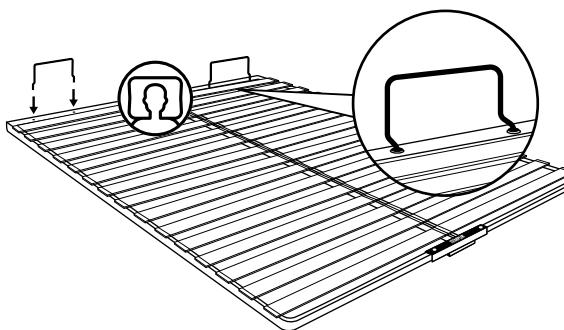

5. Carefully place the inner frames on the bed base.

Connect the frames with hinges. Align the holes on the frame with the holes on the hinge and pass the two M6 x 50 mm bolts into the holes, both sides of the frame. Place a M6 nut onto each of the M6 bolts and tighten with fingers then using the Allen key, fully tighten the bolts.

WARNING!

Please be careful not to trap your fingers in the hinges or under the bed frame.

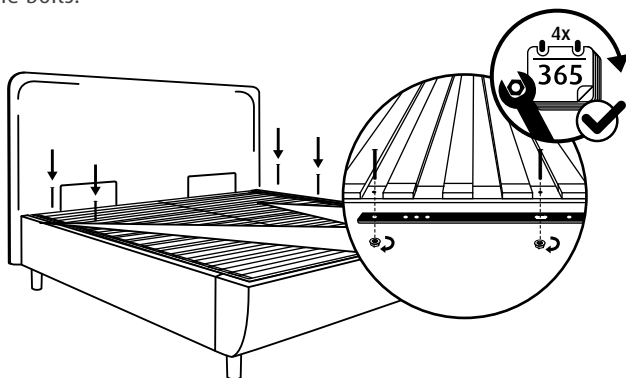

6. Connect pistons with frame and hinges. You need 2 x pistons and 4 x M8 nuts.

Add pistons to the both sides of the bed. Be aware that the piston needs to be placed in the way that the thicker side is facing upwards. While one person holds the slatted frame up, the second person must fit the piston to the hinge. You need to unscrew the prescrewed nuts. Then add pistons and rescrew the nuts and tighten them with M8 spanner.

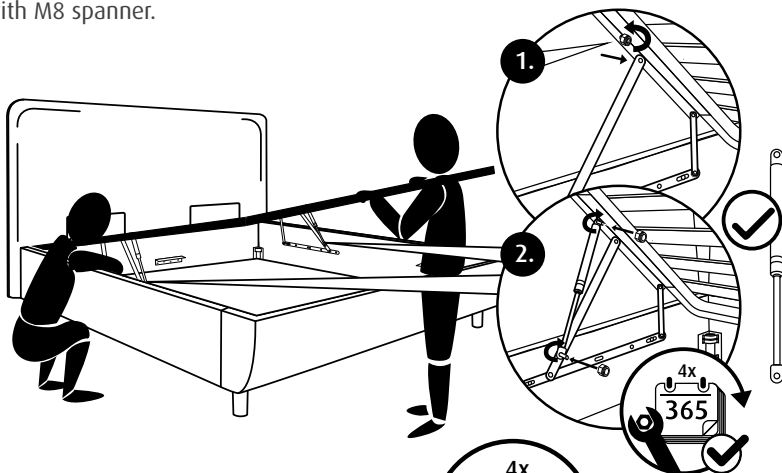

CAUTION! Check the bolts and nuts on the hinges and pistons action every few months to make sure that these are properly and firmly attached to their position.



WARNING

Don't leave the storage bed in a closed position without weight (mattress) on top of it. Especially don't leave it unattended in case you have children. The frame can spring upwards quickly and suddenly without the weight of the mattress and can cause injuries. Please make sure that children do not play with the bed.



7. One person should securely hold down the slatted section when the other is placing the mattress.

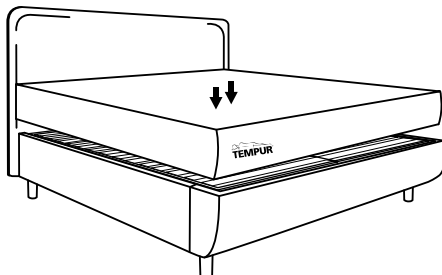

Safe opening

To open the storage, stand straight at the foot-end, in the centre. Be aware to keep your head away and a safe distance from the frame. Place your hands shoulder width apart, place them under the mattress. Grab the frame from the centre. Pull and push up the frame carefully.

WARNING!

Be careful not to hit your head while opening the frame. Be aware that during opening on the middle way up, the lifting mechanism applies a powerful force to lift the system up to the end.

WARNING!

While using the storage space, keep the storage frame fully open.

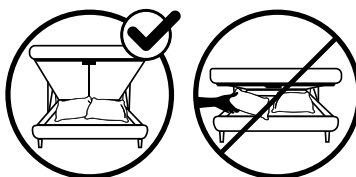

Safe closing

To close the storage, stand straight at the foot-end, in the centre. Place your hands shoulder width apart, on the top of the frame end. Make sure you place your fingers only on top of the frame end and not under nor around it. Then push the frame down to its closed position.

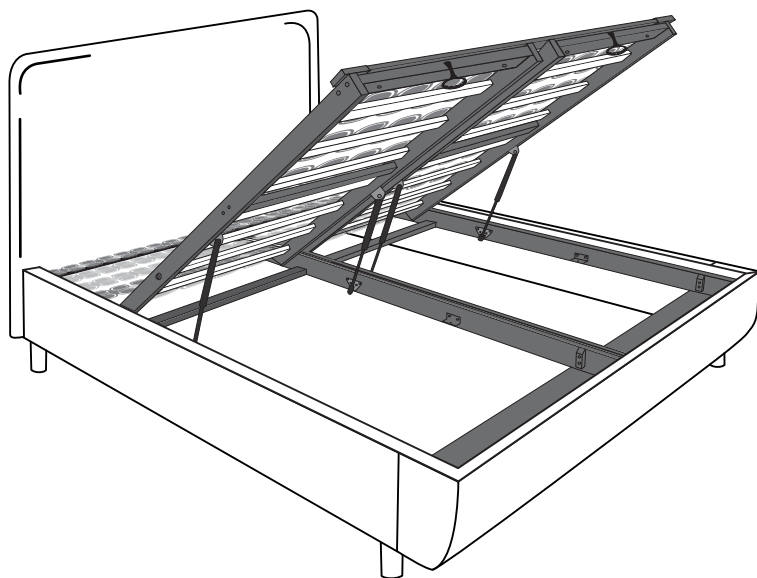
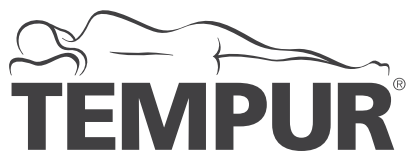

TEMPUR ARC™

Storage disc inner frames assembly guide



CAUTION

The assembly instructions must be followed closely to install the bed system successfully, safely and to minimize the risk of personal injuries and damage to the product.



Open the packaging carefully, so as not to damage the product and its parts. Dispose of the packaging safely and as sustainably as possible in your local area.



Assemble the product with two persons.



Do not trap your fingers in the hinges or under the bed if safety pin is not locked.



Keep away the pets and children during the assembly.



Warning: risk of injury when bed frame opens. Be careful to avoid being hit.



Do not allow children and/or pets to play on or under the bed.



Do not use the bed in open position without safety pin locked!

Component list

2x inner frames (left and right side)

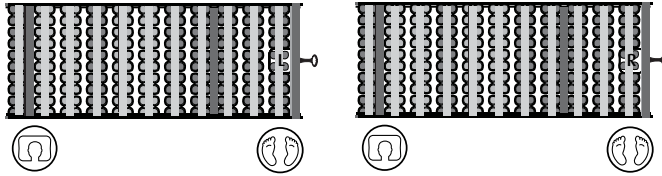

Components to join two inner frames

4x bolts

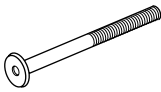

4x spacers



1x Allen key



1x connecting bar



CAUTION

Do not remove the velcro ribbon holding the inner frame together before installing it in the bed frame. Removing the ribbon may cause the frame to open and result in injuries.

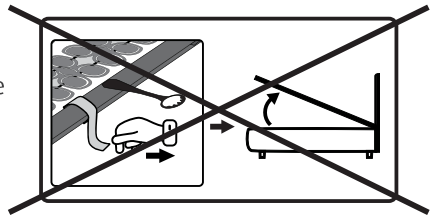

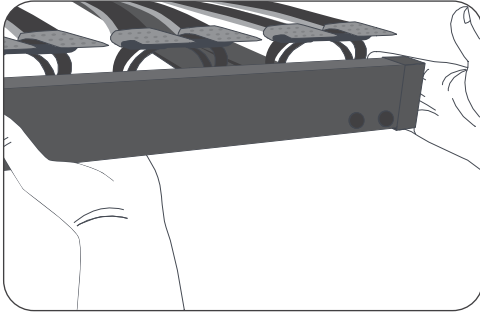

CAUTION

Lift and carry the frame with two people by holding it from the bottom support frames.

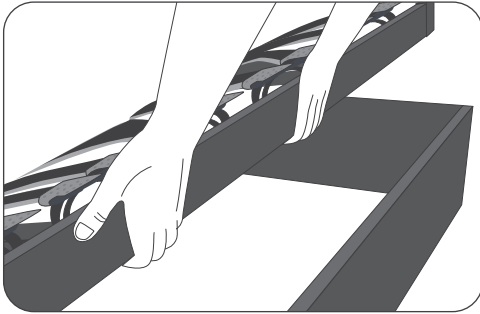

WARNING

While mounting the frames, be careful your fingers are not trapped between the outer and inner frame.

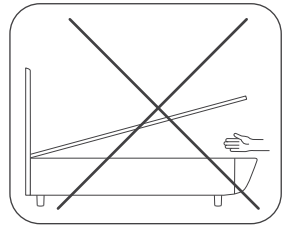

CAUTION

Be aware not to carry the frame only holding it from the middle of the slats or discs, these may come off or be damaged.

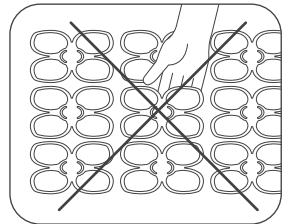

Components

Follow the direction of the frame; you have light grey discs at the head-end and handles at the foot-end.
Follow the left and right side markings on the frames, as the safety locks must remain on the sides of the bed.

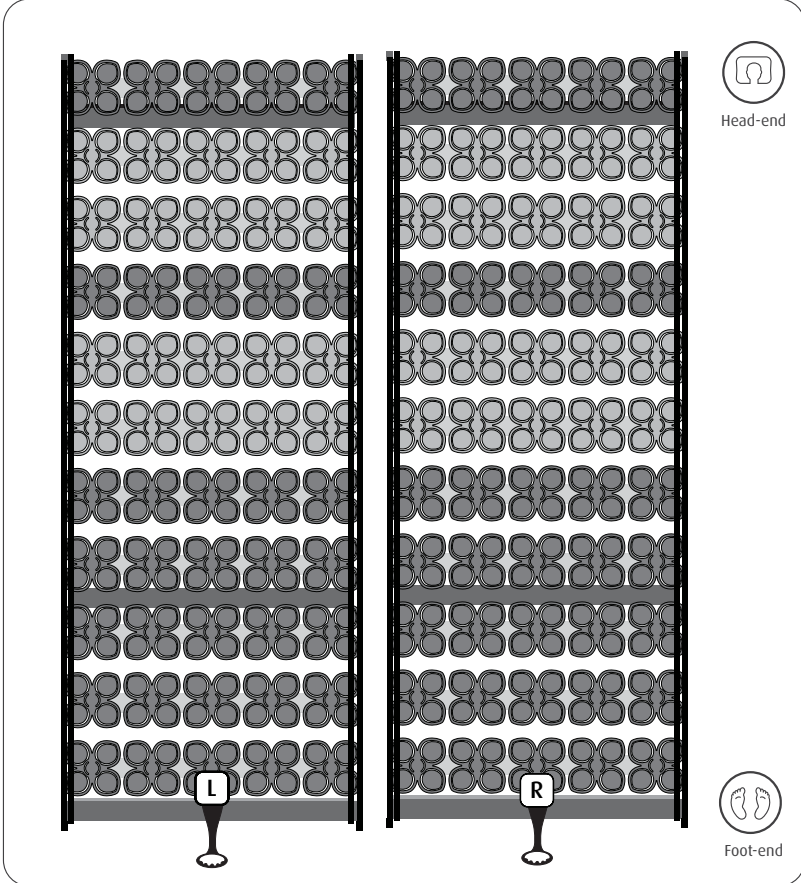

1. Insert the frame into the bed.

Take one frame with two people and turn it sideways. One person lifts the frame from the head-end and the other from the foot-end. Hold the frame from the longer side support frame. Place the frame sideways (inner side facing downwards) inside the outer frame. Install the frame head-end onto the headboard metal angle first and then the foot-end onto the bed foot-end. Drop the frame slowly sideways into a horizontal position, at the same time you need to lift the head-end so the discs do not to break.

IMPORTANT!

Place the frame marked 'L' on the left side of the bed and the frame marked 'R' on the right side of the bed.

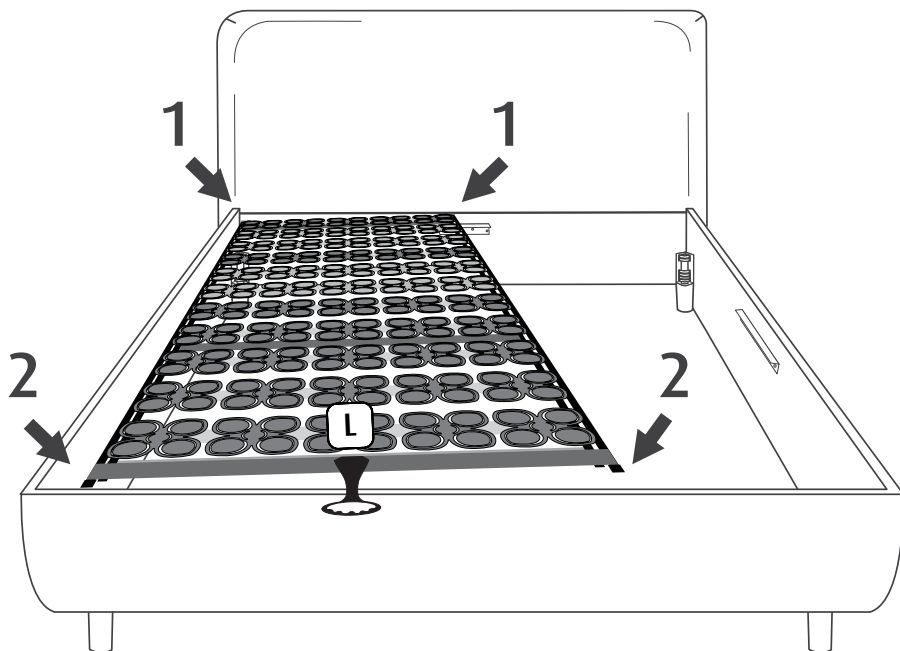

2. Add the second frame in the same way.

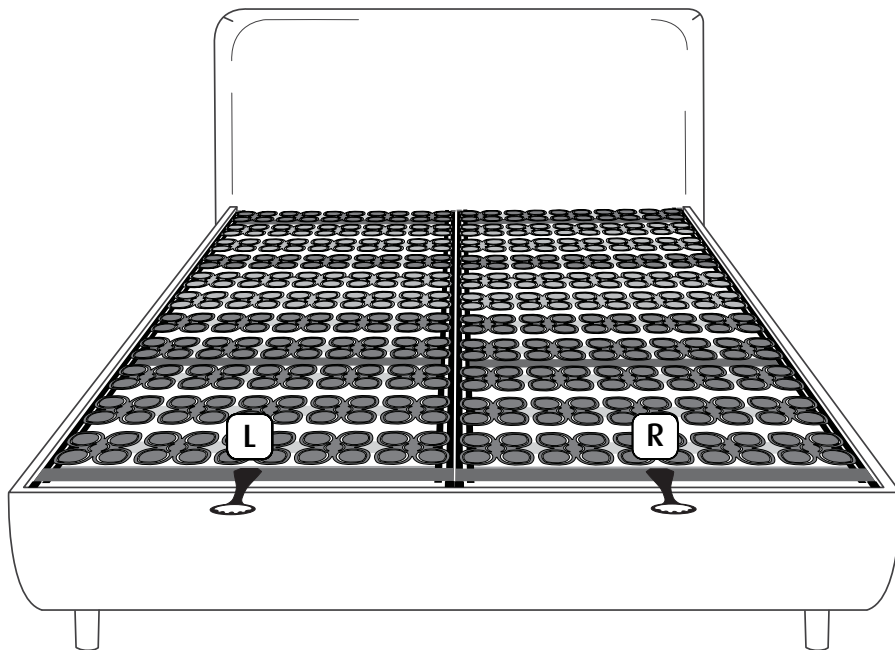

Discs are with different tensions, light grey coloured discs are softer and dark grey coloured are harder. You can change the disc positions according to your preferences.

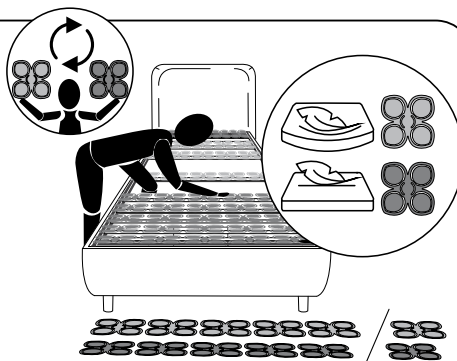

3. Remove velcro straps from the frames.

Take away one strap at a time! Secure and hold down the frame with one hand (or have second person assist) while removing the strap. Ensure the frame doesn't open unexpectedly. After removing the strap, open the frame and leave the upright part in position. After removing the strap from one frame repeat the same steps with the other frame.



WARNING!

Do not leave the storage bed in a closed position without weight (mattress) on top of it. After the strap has been removed, and if there is no weight on the frame, it may spring upwards if the bed or the frame is moved.

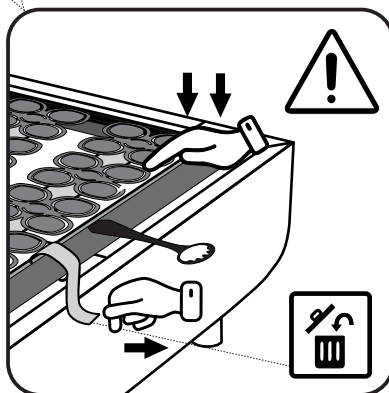
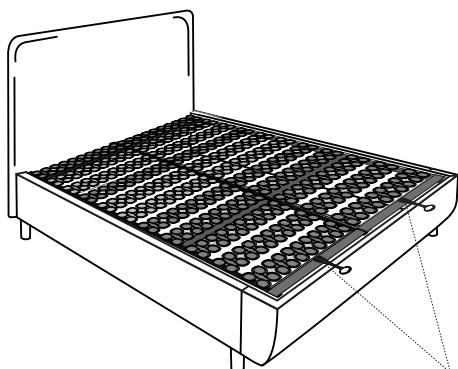

CAUTION!

When the frame is open, exercise caution during the next steps of assembly.



4. Always use the convenient support bars on both sides when using the storage area. These can be engaged once the frame is in the open position.

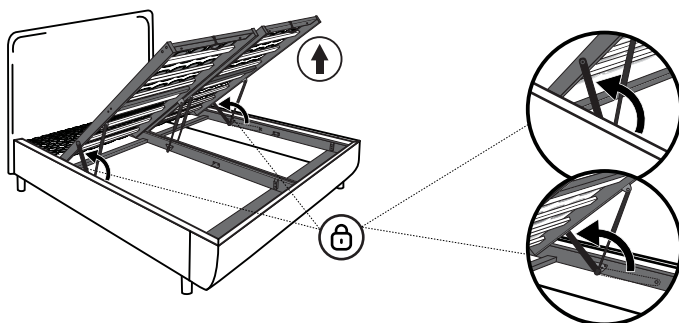

IMPORTANT!

Safety pin must always be in locked position when using the storage area.

5. Use connecting bar to connect the rising parts of the both frames. From the top side of the bed frames insert the four spacers into the holes of the slat. Attach the connecting bar to the top of the frame and fasten it with the four bolts and the allen key. A small gap should remain between the connecting bar and bed frame.

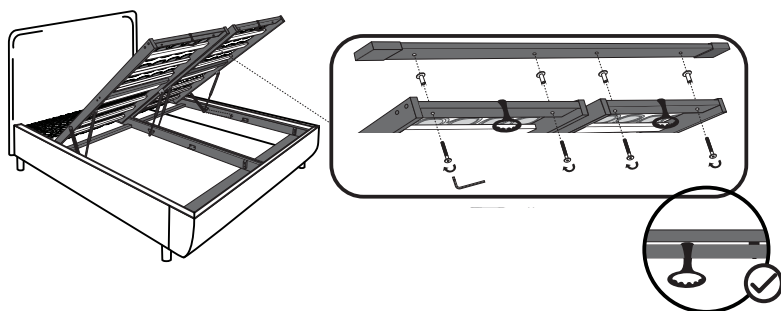

6. Release the safety arm and lower the ascending part of the bed. Release the support bar and rotate back into the unlocked position. With two people, lower the ascending part of the bed into the flat position. Keeping well clear once flat.

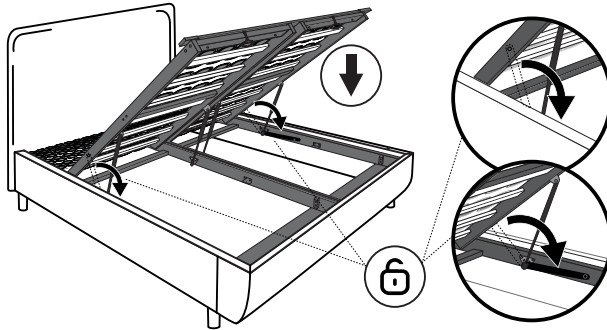

CAUTION!

Check the bolts and pistons in every few months to make sure these are properly and firmly attached.

7. Place down the mattress ensuring the bed doesn't open while doing it.

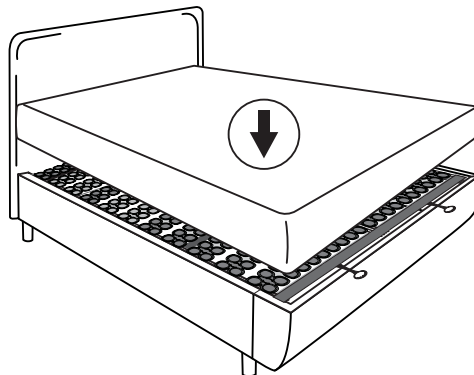



WARNING!

Don't leave the storage bed in a closed position without weight on top of it. The frame can spring upwards and can cause injuries. Be careful not to hit yourself while opening the bed.

Make sure the children and the pets doesn't have access to the bed during the assembly.

Do not allow children to open or close the bed. Supervise your pets while opening or closing the bed.

While using the storage space, always move the safety pins to the locked position.

SAFE OPENING

To open the storage, stand straight at the foot-end, in the centre. Be aware to keep your head away and a safe distance from the frame. Use the handles or grab a bed frame from the middle and pull up the frame. Move the safety pins to the locked position.

SAFE CLOSING

Disengage the safety pins, stand straight a the foot-end, in the centre. Place your hands shoulder width apart, on top of the frame end. Make sure you place only your fingers on top of the frame, not under or around it. Then push the frame down to its closed position.

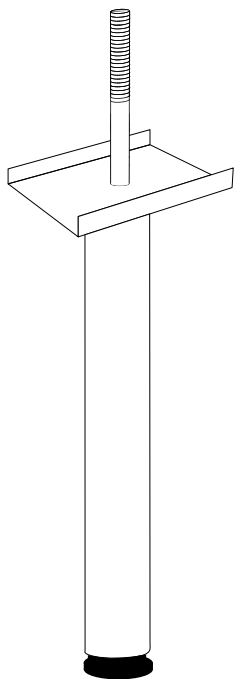

TEMPUR ARC™

Support leg assembly guide



CAUTION

The assembly instructions must be followed closely to install the bed system successfully, safely, and to minimize the risk of personal injuries and damage to the product.



Assemble the product with a minimum of two persons.



Open the packaging carefully, so as not to damage the product and its parts. Dispose of the packaging safely and as sustainably as possible in your local area.

IMPORTANT

Support leg for ARC™ beds is not usable with ARC™ Storage beds.

Component list

Check all the components. All the tools needed for assembly come with the product.

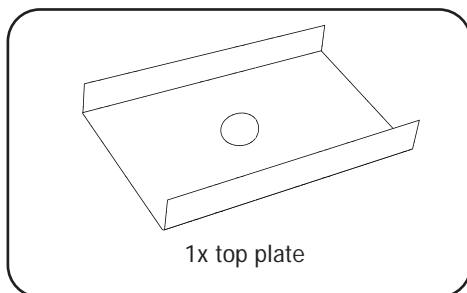
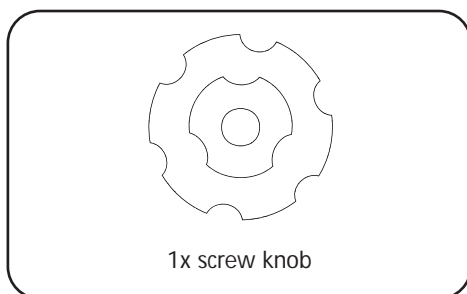
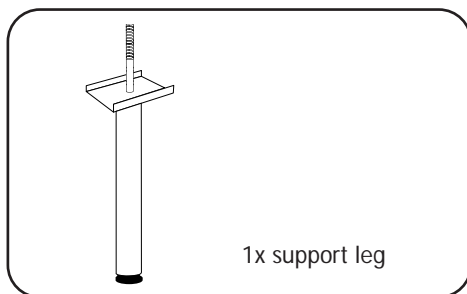

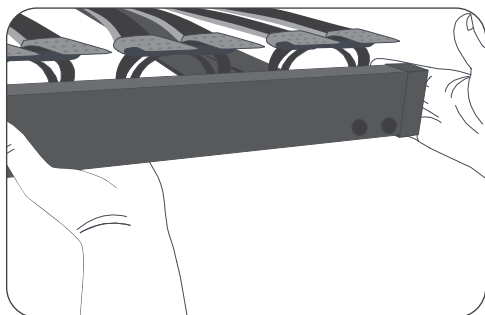

CAUTION

Lift and carry the frame with two people by holding it from the bottom support frames.

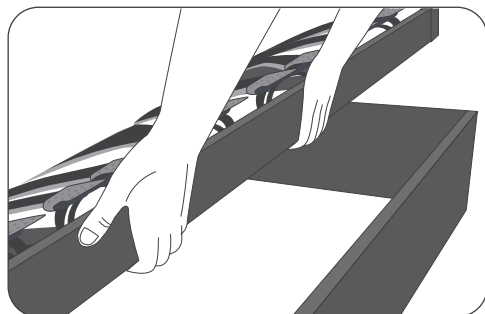

WARNING

While mounting the frames, be careful your fingers are not trapped between the outer and inner frame.

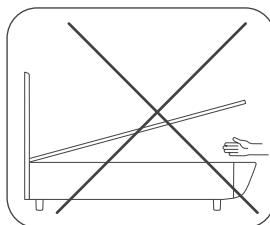

CAUTION

Be aware not to carry the frame only holding it from the middle of the slats or discs, these may come off or be damaged.

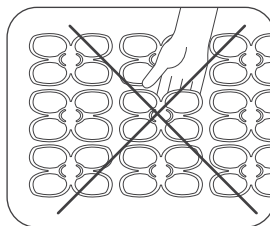

Adding the support leg to an already assembled bed.

1. On adjustable bed, lower both ends so the bed is in a completely flat position. Then remove the power cords from the outlet.

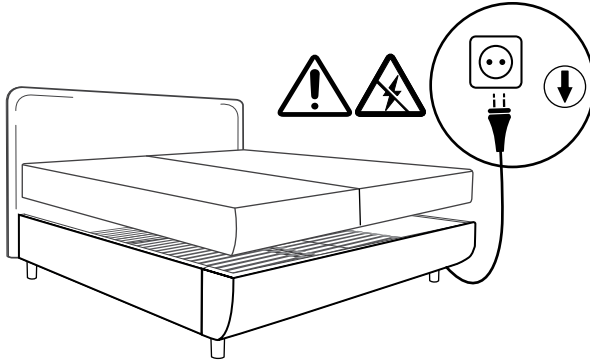

2. Remove the mattresses from the bed. Then remove one of the bed frames from inside the bed.

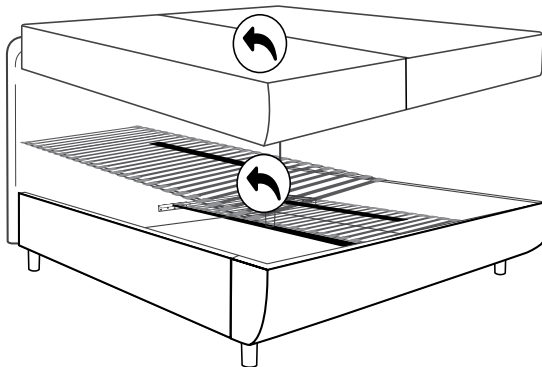

3. Insert the support leg halfway under the frame that is still inside the bed. The screw on top of the support leg must remain visible from the side of the other bed frame. Place the support leg approximately in the middle of the bed and, using the screw at the bottom of the support leg, adjust the height so it fits exactly between the bed frame and the floor.

Ensure the support leg is neither too tall nor too short, and that the bed frame rests on both ends of the bed as well as on the support leg.

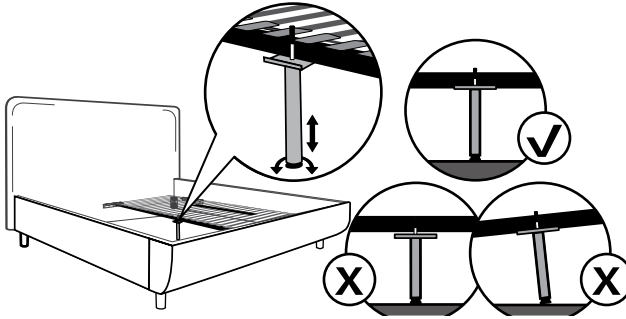

4. Put the second bed frame back into the bed so that the screw on top of the support leg stays between the two bed frames. Ensure the second bed frame rests on the bottom plate of the support leg as well as the first bed frame. Attach the top plate to the support leg so that both bed frames are clamped between the support leg's top and bottom plates. Fasten the plates with the screw knob. The knob must be fastened tightly so it doesn't come loose while using the bed.

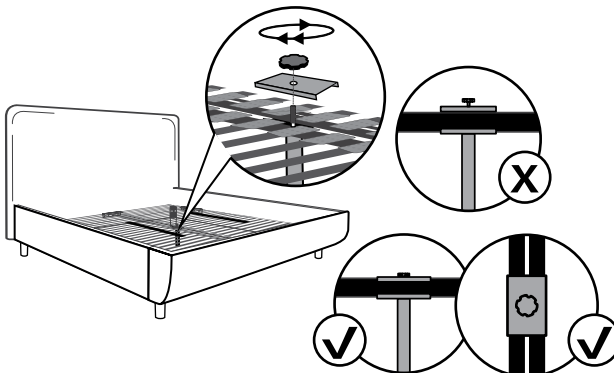

5. Put the mattresses back onto the bed. For adjustable beds, insert the power cords back into the outlets after adding the mattresses.

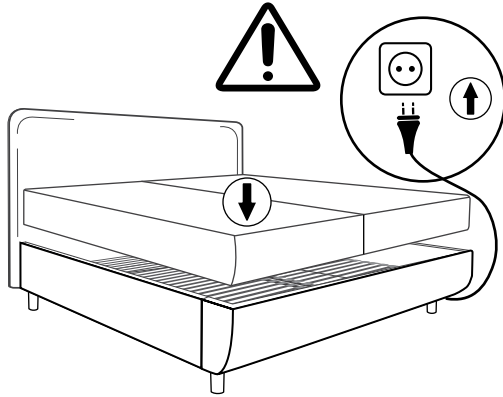

Adding the support leg during the assembly of the new bed.

While assembling the new bed, follow points 3 and 4 of this assembly guide when inserting the bed frames into the bed. Then continue following the assembly guide for the rest of the bed assembly.