

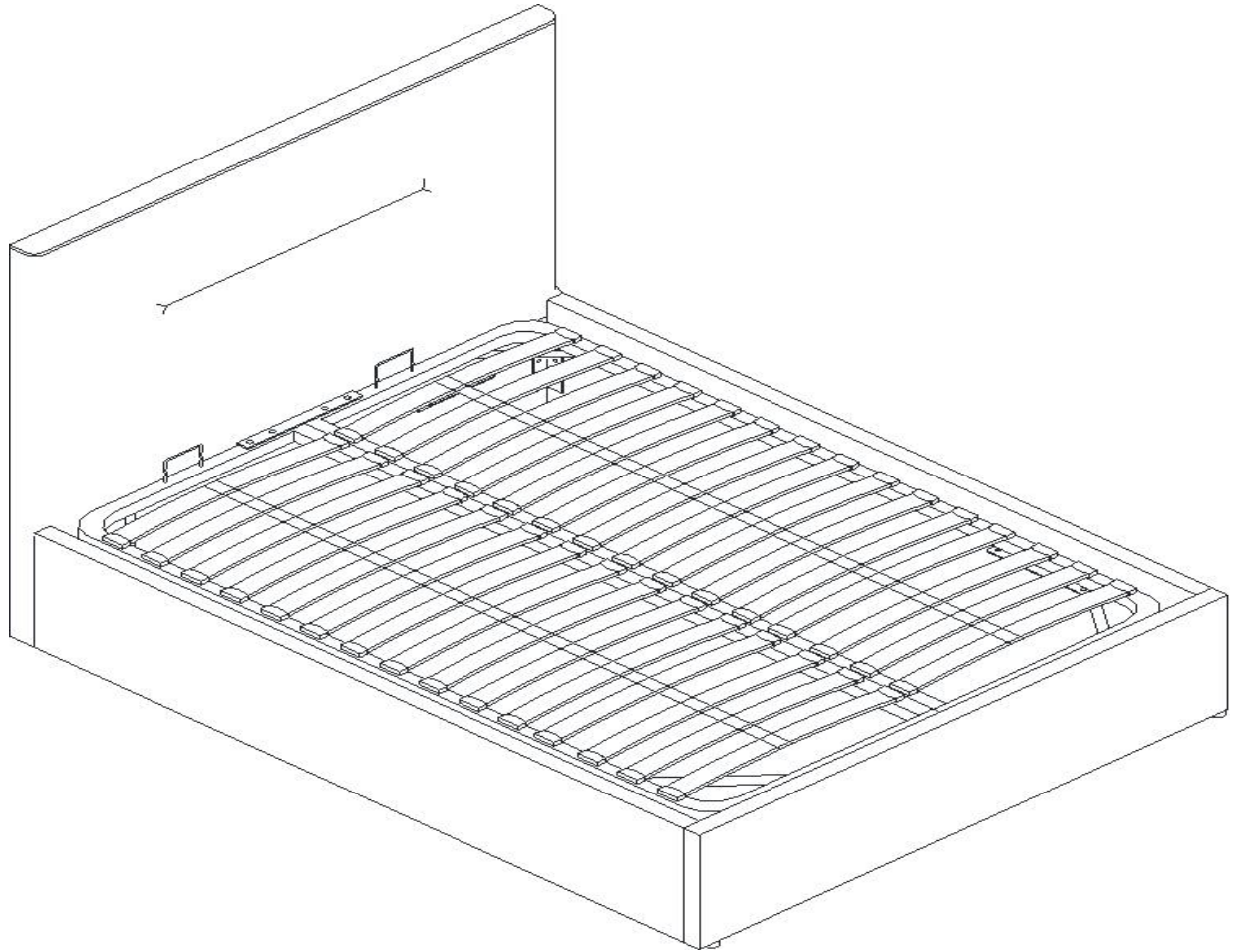

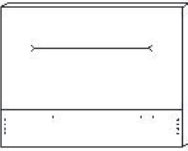















## LANGAN OTTOMAN BEDSTEAD ASSEMBLY INSTRUCTIONS



### COMPONENT LIST

						
1 x Headboard	1 x Footboard	2 x Side Rail (R & L)	2 x Slatted bed frame (R & L)	2 x Bottom Board	2 x Joining Brackets	4 x Support Brackets

### COMPONENT LIST

								
2 x Mattress Bars	28 x M8 x 20mm bolts with Washer (16 pcs attached to head/foot board)	1 x M8 x 80mm bolts with washer and nut	8 x M8 x 60mm bolts with washer and nut	6 x M6 x 60mm bolts with washer and nut	1 x 4 mm Allen Key	1 x 5 mm Allen Key	1 x 11 mm Spanner	1 x 13 mm Spanner

**SAFETY/ASSEMBLY ADVICE**

- Please take the time to carefully read through the following instructions before proceeding to build the bed
  - Prepare a clear area in the bedroom to construct the bed as close to the final position as possible.
  - Unpack and check all contents. Please dispose of plastic bags safely.
  - Keep small children away from the assembly area as small components could choke a child.
  - Two people are required for safe assembly.
- 
- Please take care when putting mattress onto slatted frame as the frame can spring open if not held in place.
  - Check bolts on the ottoman action every few months.

**STEP 1.**

1. Unpack all components and remove packaging.
2. Assemble the bed frame in the final required position in the bedroom
3. Position headboard gently against a wall or support, and position side and end panel for assembly as shown in image.
4. Unscrew mounting bolts on the head and footboard ready to accept side rail corner brackets.

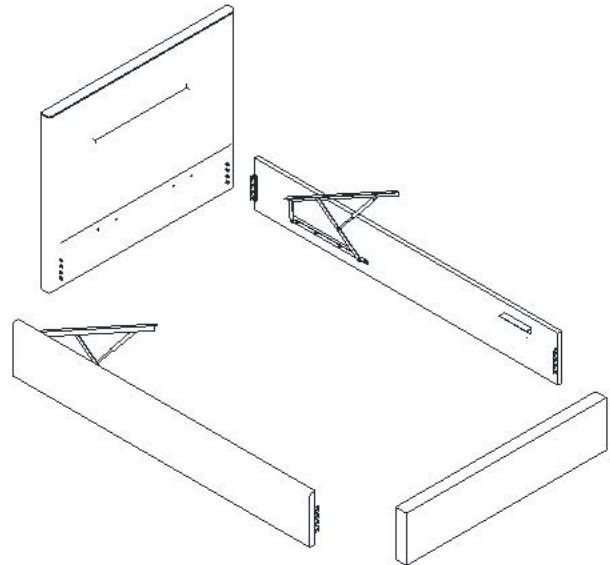
**STEP 2.**

1. Hook up side rails to headboard, and loosely tighten the bolts.
2. Repeat the same process to the footboard.
3. Ensure frame is square and level then tighten all bolts fully on head and footboard using the allen key provided as shown in the below image.

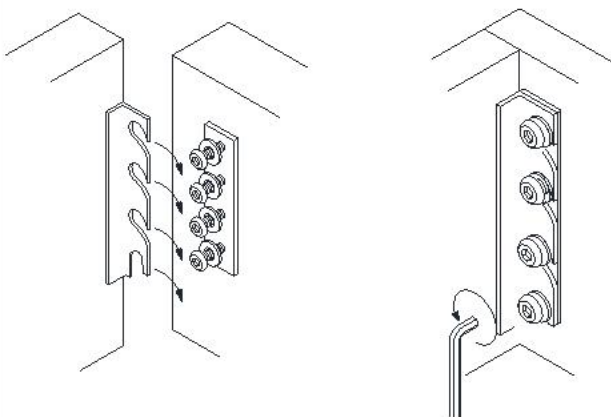
**STEP 3.**

1. Attach support brackets to headboard using the M8 x 20mm bolts and Allen key.
2. Complete the same process for the footboard.

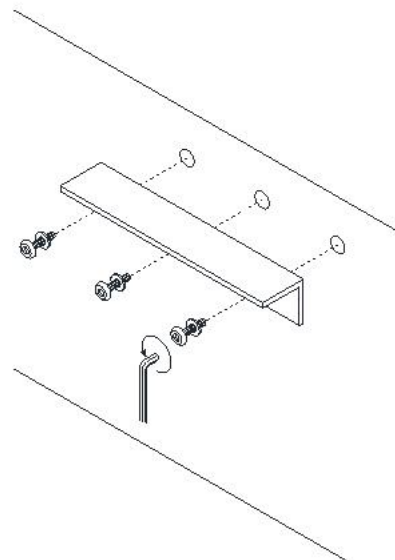

STEP 4.

1. After fitting the support brackets your bedstead is now ready for the two bottom panels.
2. This will take two people to position safely and to avoid any risk of damage.

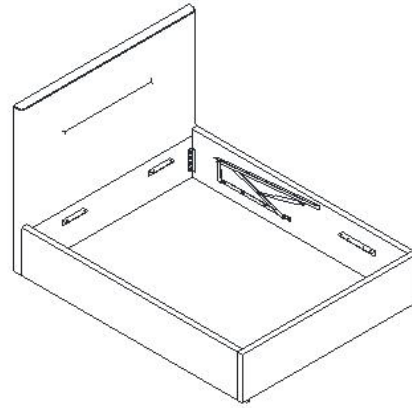

STEP 5.

1. With each person standing either side of the bed slide the bottom panels down between the hinges and support bracket. The bottom panels will rest on their plastic feet.
2. Slide the panel all the way to the head end of the bed to give enough room for the second panel.

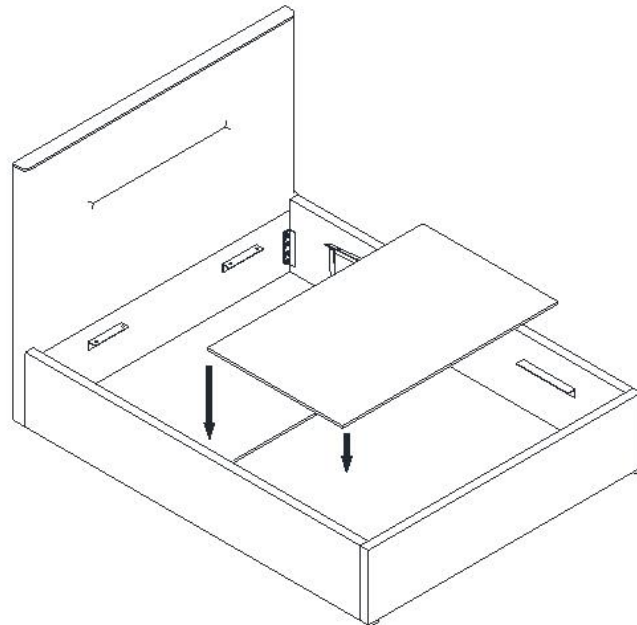

3. Again, using two people, angle the panel downwards and slot between the hinges and support brackets.
4. Slide the panel all the way to the foot end.

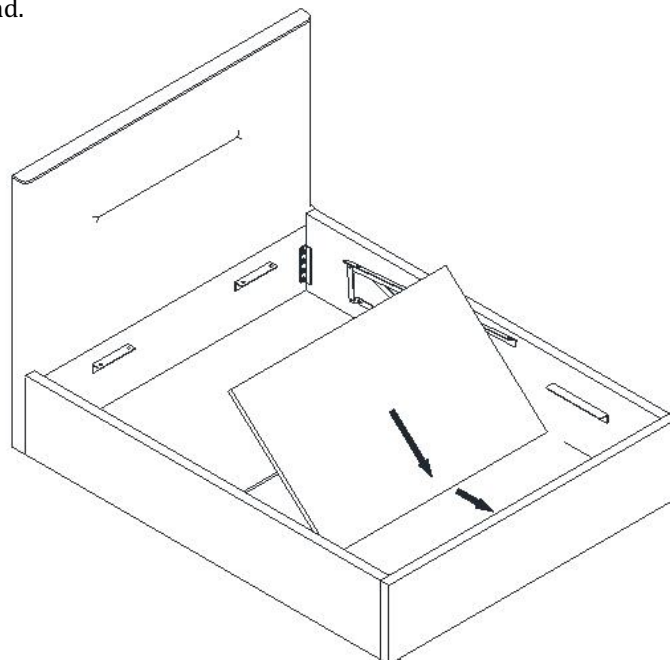

## STEP 6.

1. Unwrap the slatted frames and dispose of the packaging.
2. Push both frames together along the length of the frames.
3. Join the two halves together using the M8 x 80mm bolt through the holes and tighten with the M8 nut.

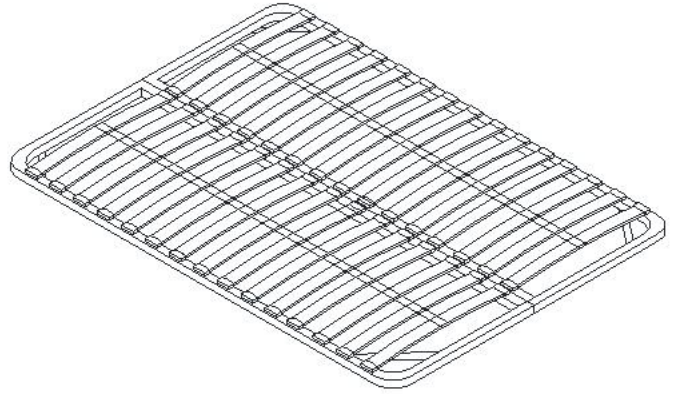
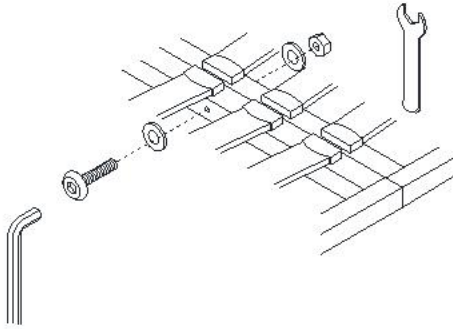

## STEP 7.

1. Clip the two joining brackets over the center of both the head and foot ends.
2. Line up the holes on the joining bracket to the holes on the frames.
3. Slot the M8 x 60mm bolts through the holes and tighten with the M8 nuts. Complete at head and foot end of frame.

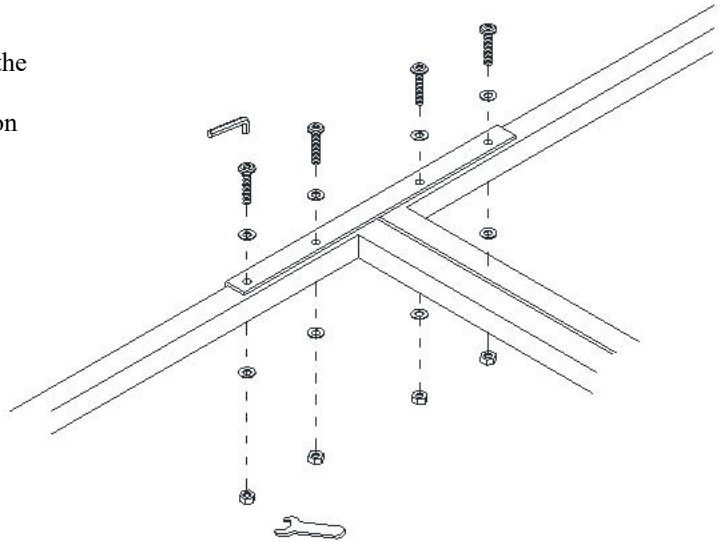

## STEP 8.

1. Push the two mattress bars into the holes both sides of the head end of the frame.
2. The slatted frames are now joined and ready to fix to the hinges and base.

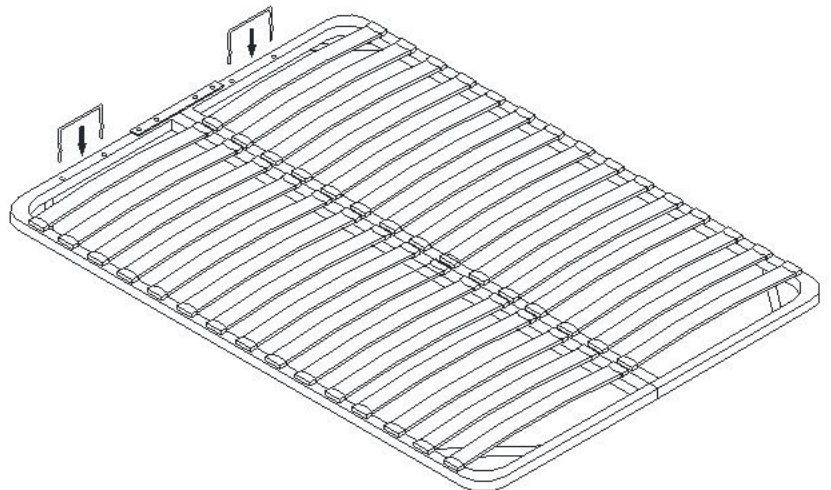



**STEP 9.** **WARNING:** Please take care not to trap your fingers in the hinges.

1. While one person holds the slatted frame up, the second person should fit the gas strut to the hinge.
2. One end of the strut will already be attached to the hinge. For the other end take the nut off the bolt, and attach the other end of the strut.
3. Once this is in place, replace and tighten the nut.
4. Repeat process for the other side of the bed.

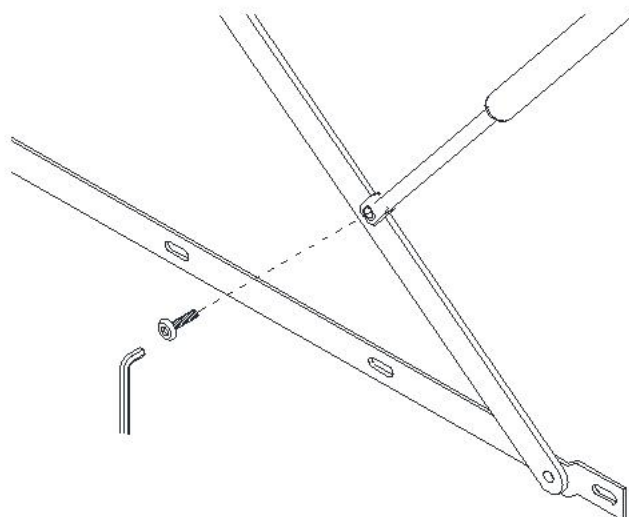

**STEP 10.**

1. Identify the head end of your slatted frame, this will be the end with holes.
2. Carefully lower the slatted frame into the base so that it rests on the hinges and the support brackets. Again, this will require two people to do safely.
3. Align the holes on the frame with the holes on the hinge and pass the three M6 x 60mm bolts through the washers provided and then into the holes each side of the frame.
4. Place a nut onto each of the M6 bolts and tighten with fingers, then, using the Allen key provided, fully tighten.
5. The slatted frame and base are now joined.

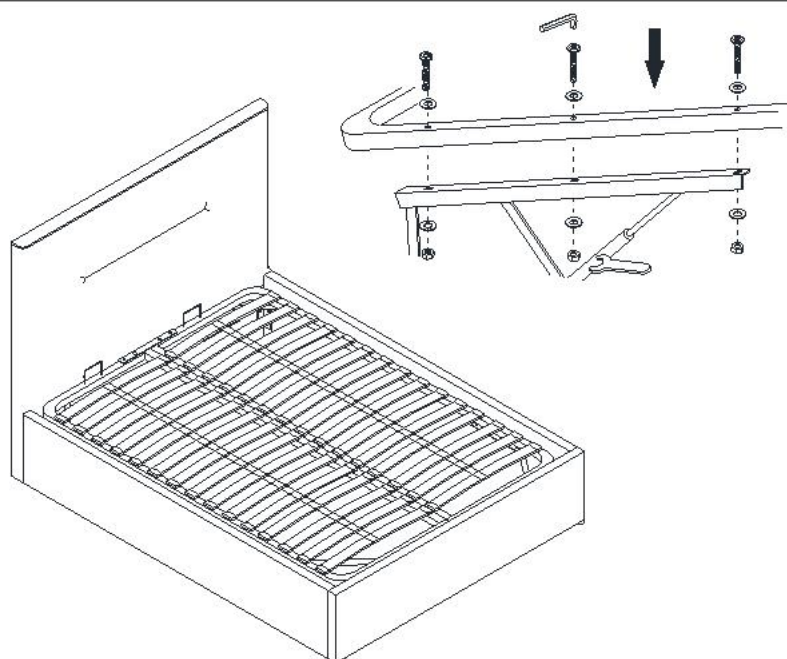

**STEP 11.**

**WARNING:** Please take care when putting mattress onto frame

1. Once both struts are fixed to the hinges the bedstead is now ready for the mattress.
2. Place mattress on top of the frame. Take care when doing this as the frame can spring upwards without the weight of the mattress.

